

Helion Technology

FULL DATASHEET – Common Scrambling Algorithm Cores for Actel FPGA

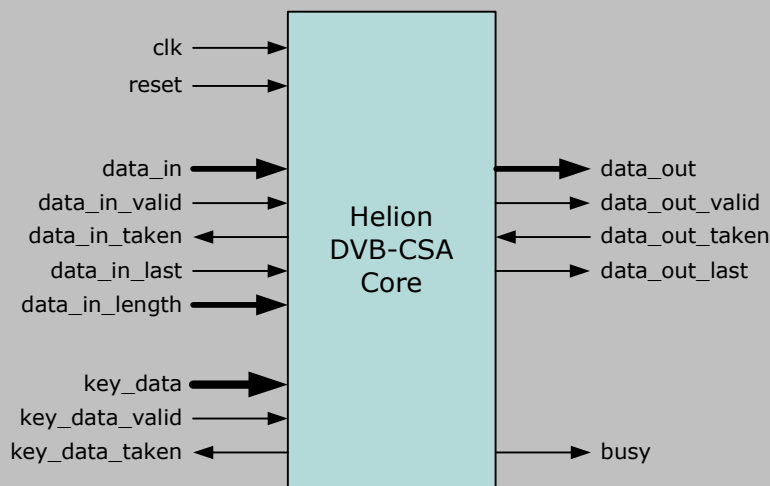

Features

- Implements ETSI specified DVB Common Scrambling Algorithm
- Ideal for use in BISS-E and BISS Mode-1 Digital Satellite News Gathering applications
- Available as separate Scrambler and Descrambler cores for optimum system efficiency
- Internal 3-stage pipeline for optimum Scrambler data throughput
- Capable of Scrambler/Descrambler data throughputs up to 400 Mbps
- Simple interfacing to user logic with separate key and data ports
- Optimised for use in Actel Flash and Antifuse FPGA families

Deliverables

- Target specific netlist or fully synthesisable RTL VHDL/Verilog
- VHDL/Verilog simulation model and testbench with ETSI test vectors
- Comprehensive user documentation

Overview

The Helion DVB-CSA cores implement the ETSI specified Common Scrambling Algorithm (CSA) which is used to provide the conditional access mechanism for MPEG-2 video streams for use in Pay-TV systems adopted by Digital Video Broadcasting (DVB) consortium. It has also been specified by the European Broadcasting Union (EBU) for use within Digital Satellite News Gathering (DSNG) applications, where it provides data security within the Basic Interoperable Scrambling System (BISS) Mode 1 and Mode E specifications.

Both cores have been designed especially for use in each different Actel FPGA technology to provide high performance combined with low resource utilisation. They can support DVB scrambling and descrambling applications capable of data throughputs in excess of 100 Mbps.

Helion Technology Limited

Ash House, Breckenwood Road,
Fulbourn, Cambridge CB21 5DQ, England



Functional Description

The Helion DVB-CSA Scrambler core encrypts transport stream payloads using a two-stage process. Due to the nature of the scrambling algorithm, each complete payload must be transferred into the core by the user application before encryption can begin. As a first stage the CSA encrypts the payload using a block cipher starting at the end of the payload and working towards the start of the payload. The second stage applies a stream cipher to the output from the block cipher, which is used to further encrypt the data in the forwards direction i.e. beginning at the front and working towards the end of the partially encrypted payload.

The Helion DVB-CSA Descrambler core decrypts scrambled transport stream payloads using the reverse two-stage process to the Scrambler core. First it initialises the stream cipher and decrypts the data beginning at the start of the payload. It then applies the block cipher to the output of the stream cipher in the forward direction i.e. working from the front towards the end of the payload. This completes the descrambling process to recover the original unencrypted transport stream payload.

Both cores use a simple synchronous handshaking protocol to transfer data between the core and the user logic. A separate 64-bit key interface is used to load the CSA common key into the cores.

Logic Utilisation and Performance

Helion is proud to be a founding member of the Actel CompanionCore IP program. We therefore take our Actel IP core implementations very seriously. Our cores have been designed from the ground up to be highly optimal in each different Actel FPGA technology; they are not simply based on generic ASIC RTL like much of the competition. In this way we achieve the very best combination of low resource usage and high performance.

The Helion DVB-CSA Scrambler and Descrambler cores have been specifically designed to be highly optimal in both Actel Flash and Antifuse devices. The table below shows typical resource usage and performance. If the Actel device family you are interested in is not shown in the table below, please contact Helion for more details.

	Scrambler		Descrambler	
technology	ProASIC3 -2	Axcelerator -2	ProASIC3 -2	Axcelerator -2
logic resource	2265 tiles 3 RAMs	TBA TBA	2133 tiles 1 RAM	TBA TBA
max clock	98 MHz	TBA	102 MHz	TBA
max throughput	105 Mbps	xxx	110 Mbps	xxx

NOTE: We are only able to license these cores to customers that have signed the ETSI Non-Disclosure Agreement and are in possession of a valid license to use the Common Scrambling Algorithm.

More Information

For more detailed information on this or any of our other products and services, please contact Helion and we will be pleased to discuss how we can assist with your individual requirements.



Helion Technology Limited

Ash House, Breckenwood Road,
Fulbourn, Cambridge CB21 5DQ, England

tel: +44 (0)1223 500 924 email: info@heliontech.com
fax: +44 (0)1223 500 923 web: www.heliontech.com