



EIA Standard Board Layout Drawing for BGA, CCGA, CSP, and QFN

July 2009

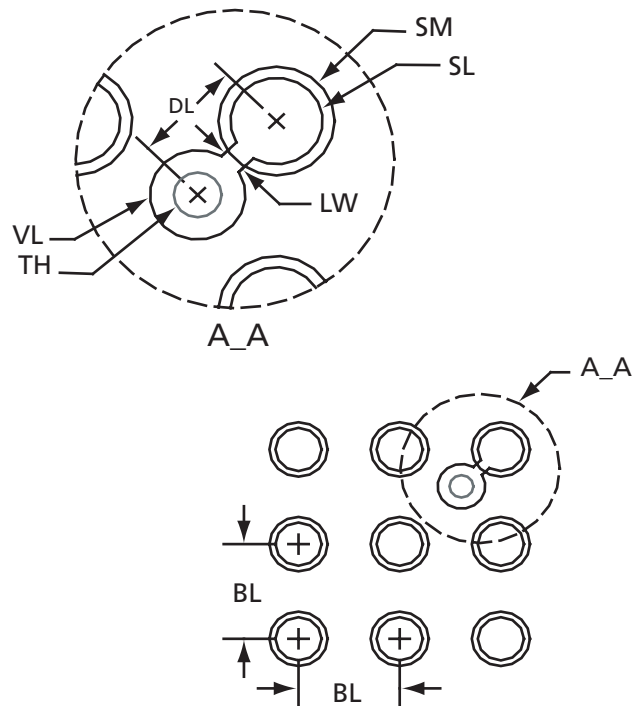

Figure 1: Suggested Board Layout of Soldered Pads for BGA Packages

Notes:

1. Table 2a through Table 6 on page 11 contain the recommended guidelines for board layout soldered pad dimensions for the following Actel packages (including pad dimension for prototyping socket accordingly): **CS** (Chip Scale BGA, 0.8 mm pitch), **FG** (Fine Pitch BGA, 1.00 mm pitch), **BG** (Plastic Ball Grid Array, 1.27 mm pitch), **CG** (Ceramic Column Grid Array, 1.27 mm pitch), CG adapter socket, **QN** (Quad Fine Pitch No-Lead QFN, 0.5 mm pitch).
2. For E-tec prototyping socket soldering, Actel recommends using non-silver type solder paste with 6 mils thickness.

Table 1a: Recommended PCB design guidelines for Actel CS (0.5 mm pitch BGA) package

Dim.	uCS36	uCS81	CS81	CS121	CS196	CS201	CS281
Component Land Pad Diameter (SMD)	0.33	0.33	0.35	0.35	0.35	0.35	0.35
Solder Land Diameter (SL)	0.23	0.23	0.25	0.25	0.25	0.25	0.25
Solder Mask Opening Diameter (SM)	0.33	0.33	0.35	0.35	0.35	0.35	0.35
Solder Ball Land Pitch (BL)	0.4	0.4	0.50	0.50	0.50	0.50	0.50
Line Width Between Via and Solder Land (LW)	Via In Pad	Via In Pad	0.15 to 0.20	0.15 to 0.20	0.15 to 0.20	0.15 to 0.20	0.15 to 0.20
Distance Between Via and Solder Land (DL)	Via In Pad	Via In Pad	0.353	0.353	0.353	0.353	0.353
Via Land Diameter (VL)	See Land Diameter	See Land Diameter	0.200 to 0.250	0.200 to 0.250	0.200 to 0.250	0.200 to 0.250	0.200 to 0.250
Through Hole Diameter (TH)	0.100 to 0.125	0.100 to 0.125	0.100 to 0.125	0.100 to 0.125	0.100 to 0.125	0.100 to 0.125	0.100 to 0.125
Line Width (L)	0.075	0.075	0.075	0.075	0.075	0.075	0.075
Line Width (L) If Inner Outer Via's Staggered.	NA	NA	NA	NA	NA	NA	0.10
Line Space (S)	0.085	0.085	0.085	0.085	0.085	0.085	0.085
Pad Array	Full	Full	Full	Full	Full	Perimeter	Perimeter
Pad Matrix	6 x 6	9 x 9	9x9	11x11	14x14	15x15	19x19
Periphery Rows	–	–	–	–	–	4, 1, 5	2, 2, 7

Table 2a: Recommended PCB Design Guidelines for Actel CS (0.8 mm Pitch BGA) Package

Dimension	CS49	CS128	CS180
Component Land Pad Diameter (SMD)	0.35	0.35	0.35
Solder Land Diameter (SL)	0.30	0.30	0.30
Solder Mask Opening Diameter (SM)	0.45	0.45	0.45
Solder Ball Land Pitch (BL)	0.80	0.80	0.80
Line Width Between Via and Solder Land (LW)	0.15	0.15	0.15
Distance Between Via and Solder Land (DL)	0.56	0.56	0.56
Via Land Diameter (VL)	0.50	0.50	0.50
Through Hole Diameter (TH)	0.25	0.25	0.25
Pad Array	Full	Perimeter	Perimeter
Pad Matrix	7x7	12x12	14x14
Periphery Rows	–	4	5

Table 2b: Recommended PCB Design Guidelines for Prototyping Socket of CS Package

Dimension	CS49 Prototyping Socket. Actel P/N: SE-CS49-H	CS128 Prototyping Socket. Actel P/N: SE-CS128-H	CS180 Prototyping Socket. Actel P/N: SE-CS180-H
Socket Pin Diameter	0.45	0.45	0.45
Solder Land Diameter (SL)	0.50	0.50	0.50
Solder Mask Opening Diameter (SM)	0.60	0.60	0.60
Solder Ball Land Pitch (BL)	0.80	0.80	0.80
Line Width Between Via and Solder Land (LW)	0.15	0.15	0.15
Distance Between Via and Solder Land (DL)	0.56	0.56	0.56
Via Land Diameter (VL)	0.50	0.50	0.50
Through Hole Diameter (TH)	0.25	0.25	0.25
Pad Array	Full	Perimeter	Perimeter
Pad Matrix	7x7	12x12	14x14
Periphery Rows	–	4	5

Table 3a: Recommended PCB Design Guidelines for Actel FG (1.00 mm Pitch BGA) Package

Dimension	FG144	FG256	FG324	FG484 23x23	FG484	FG676	FG896	FG1152
Component Land Pad Diameter (SMD)	0.40	0.45	0.45	0.45	0.45	0.45	0.45	0.45
Solder Land Diameter (SL)	0.35	0.40	0.40	0.40	0.40	0.40	0.40	0.40
Solder Mask Opening Diameter (SM)	0.50	0.55	0.55	0.55	0.55	0.55	0.55	0.55
Solder Ball Land Pitch (BL)	1.00	1.00	1.00	1.00	1.00	1.00	1.00	1.00
Line Width Between Via and Solder Land (LW)	0.15	0.15	0.15	0.15	0.15	0.15	0.15	0.15
Distance Between Via and Solder Land (DL)	0.70	0.70	0.70	0.70	0.70	0.70	0.70	0.70
Via Land Diameter (VL)	0.60	0.60	0.60	0.60	0.60	0.60	0.60	0.60
Through Hole Diameter (TH)	0.30	0.30	0.30	0.30	0.30	0.30	0.30	0.30
Pad Array	Full	Full	Full	Full	Perimeter	Full	Full	Full
Pad Matrix	12x12	16x16	18x18	22x22	26x26	26x26	30x30	34x34
Periphery Rows	–	–	–	–	5 + 8x8	–	–	–

Table 3b: Recommended PCB Design Guidelines for Prototyping Socket of FG Package

Dimension	FG144 Prototyping Socket. Actel P/N: SE-FG144-H	FG256 Prototyping Socket. Actel P/N: SE-FG256-HU	FG324 Prototyping Socket. Actel P/N: SE-FG324-H	FG484 23x23 Prototyping Socket. Actel P/N: SE-FG484-S-H	FG484 Prototyping Socket. Actel P/N: SE-FG484-H	FG676 Prototyping Socket. Actel P/N: SE-FG676-H	FG896 Prototyping Socket. Actel P/N: SE-FG896	FG1152 Prototyping Socket. Actel P/N: SE-FG1152
Socket Pin Diameter	0.45	0.45	0.45	0.45	0.45	0.45	0.45	0.45
Solder Land Diameter (SL)	0.58	0.58	0.58	0.58	0.58	0.58	0.58	0.58
Solder Mask Opening Diameter (SM)	0.73	0.73	0.73	0.73	0.73	0.73	0.73	0.73
Solder Ball Land Pitch (BL)	1.00	1.00	1.00	1.00	1.00	1.00	1.00	1.00
Line Width Between Via and Solder Land (LW)	0.15	0.15	0.15	0.15	0.15	0.15	0.15	0.15
Distance Between Via and Solder Land (DL)	0.70	0.70	0.70	0.70	0.70	0.70	0.70	0.70
Via Land Diameter (VL)	0.60	0.60	0.60	0.60	0.60	0.60	0.60	0.60
Through Hole Diameter (TH)	0.30	0.30	0.30	0.30	0.30	0.30	0.30	0.30
Pad Array	Full	Full	Full	Full	Perimeter	Full	Full	Full
Pad Matrix	12x12	16x16	18x18	22x22	26x26	26x26	30x30	34x34
Periphery Rows	–	–	–	–	5 + 8x8	–	–	–

Table 4a: Recommended PCB Design Guidelines for Actel BG (1.27 mm Pitch BGA) Package

Dimension	BG272	BG313	BG329	BG456	BG729
Component Land Pad Diameter (SMD)	0.63	0.63	0.63	0.63	0.63
Solder Land Diameter (SL)	0.58	0.58	0.58	0.58	.058
Solder Mask Opening Diameter (SM)	0.73	0.73	0.73	0.73	0.73
Solder Ball Land Pitch (BL)	1.27	1.27	1.27	1.27	1.27
Line Width Between Via and Solder Land (LW)	0.15	0.15	0.15	0.15	0.15
Distance Between Via and Solder Land (DL)	0.80	0.80	0.80	0.80	0.80
Via Land Diameter (VL)	0.60	0.60	0.60	0.60	0.60
Through Hole Diameter (TH)	0.30	0.30	0.30	0.30	0.30
Pad Array	Perimeter	Staggered	Perimeter	Perimeter	Full
Pad Matrix	20x20	25x25	23x23	26x26	27x27
Periphery Rows	4 + 4x4	–	4 + 5x5	5 + 6x6	–

Table 4b: Recommended PCB Design Guidelines for Prototyping Socket of BG Package

Dimension	BG272 Prototyping Socket. Actel P/N: SM-BG272-B	BG313 Prototyping Socket. Actel P/N: SM-BG313-B	BG329 Prototyping Socket. Actel P/N: SM-BG329-B	BG456 Prototyping Socket. Actel P/N: SM-BG456-B	BG729 Prototyping Socket. Actel P/N: SE-BG729
Socket Pin Diameter	0.55	0.55	0.55	0.55	0.55
Solder Land Diameter (SL)	0.58	0.58	0.58	0.58	.058
Solder Mask Opening Diameter (SM)	0.73	0.73	0.73	0.73	0.73
Solder Ball Land Pitch (BL)	1.27	1.27	1.27	1.27	1.27
Line Width Between Via and Solder Land (LW)	0.15	0.15	0.15	0.15	0.15
Distance Between Via and Solder Land (DL)	0.80	0.80	0.80	0.80	0.80
Via Land Diameter (VL)	0.60	0.60	0.60	0.60	0.60
Through Hole Diameter (TH)	0.30	0.30	0.30	0.30	0.30
Pad Array	Perimeter	Staggered	Perimeter	Perimeter	Full
Pad Matrix	20x20	25x25	23x23	26x26	27x27
Periphery Rows	4 + 4x4	–	4 + 5x5	5 + 6x6	–

Figure 2: Recommended PCB Design Guidelines for Actel CCGA (Ceramic Column Grid Array, or CG) Package

Table 5: Recommended PCB Design Guidelines for Actel CCGA (Ceramic Column Grid Array, or CG) Package

The recommended guidelines for the 1.27 mm pitch package pertain to the Actel CG624 package, the CG624 to FG484 Adapter Socket, and the CG624 to FG896 Adapter Socket. The 1.00 mm pitch recommendations relate to the Actel CG1152 and CG1272 packages.

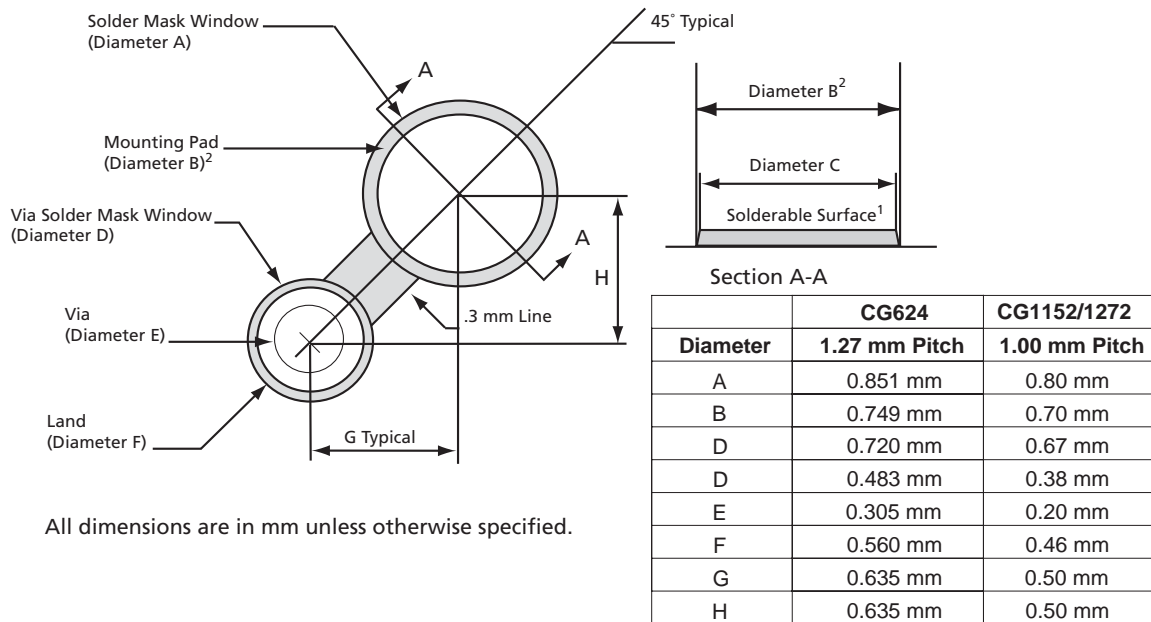

Notes:

1. Functional surface
2. Normal diameter at Copper/Polyimide interface with typical edge angle

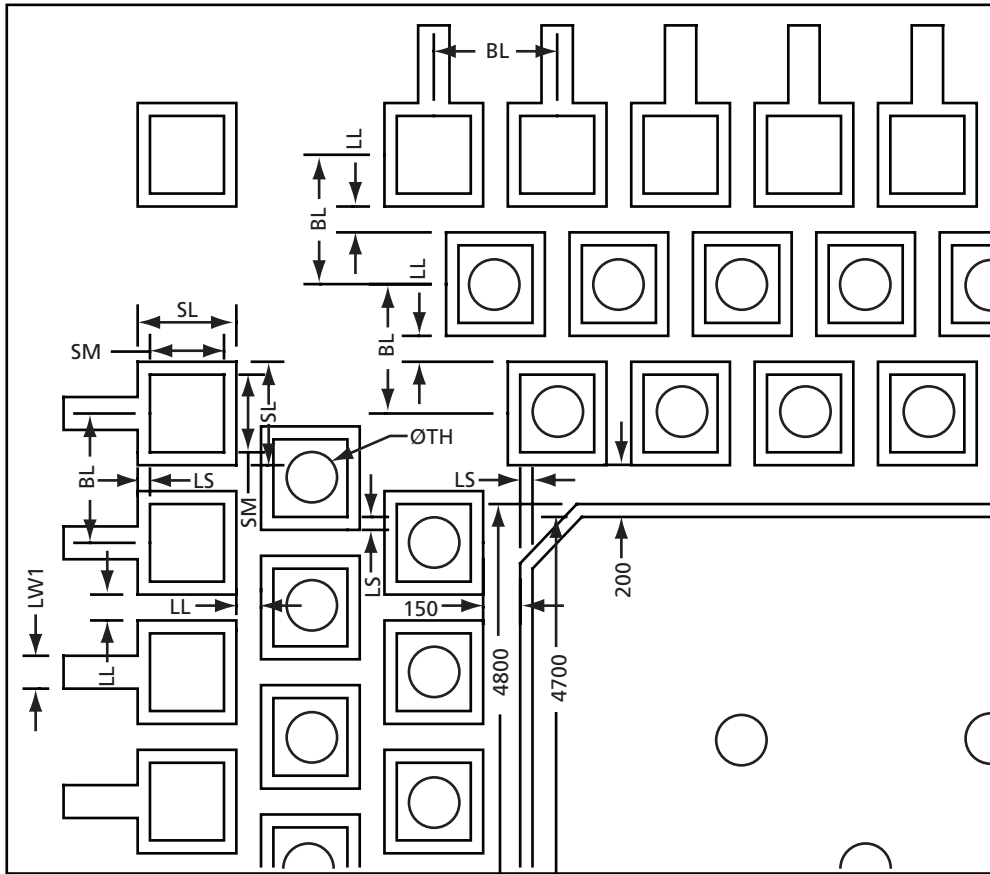

Note: This suggested board layout is for SMD. To use NSMD, swap SL and SM dimensions.
Figure 3: Suggested Board Layout of Soldered Pads for QFN (Top) Packages

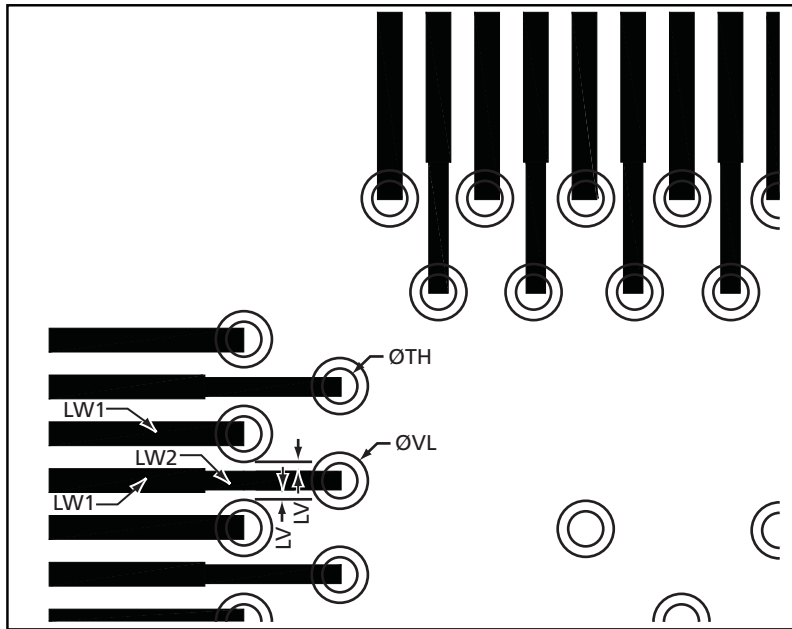

Figure 4: Suggested Board Layout of Soldered Pads for QFN (Bottom) Packages

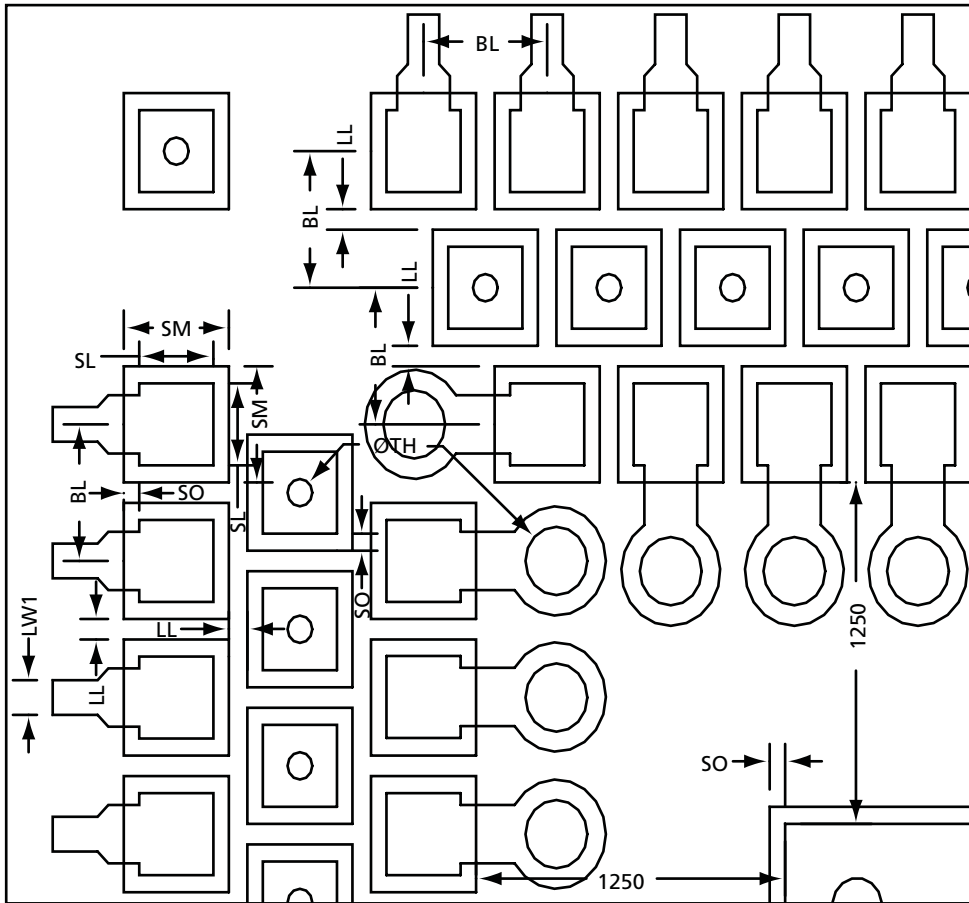

Figure 5: Suggested Board Layout of Soldered Pads for QFN Packages (PCB Bottom Layer)
 This Suggested board layout is for reduced thermal pad, NSMD, to use SMD swap SL and SM dimensions.

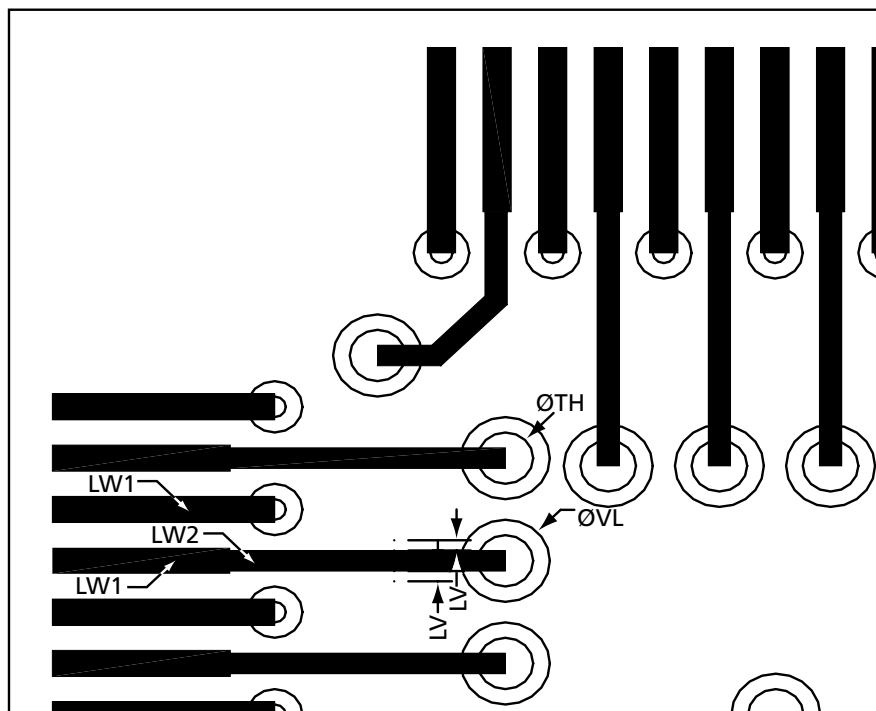

Figure 6: Suggested Board Layout of Soldered Pads for QFN Packages (PCB Bottom Layer), Reduced Thermal Pad

Table 6 contains the recommended Guidelines for board layout soldered pad dimension for Actel QN (0.5 mm pitch QFN) packages only.

Table 6: Recommended QFN Design Guidelines

Dimension	QN68*	QN108	QN132	QN180
Component Land Pad Diameter (SMD)	0.200/0.400	0.3	0.3	0.3
Solder Land Diameter (SL)	0.200/0.400	0.3	0.3	0.3
Solder Mask Opening Diameter (SM)	0.300/0.500	0.425	0.425	0.425
Solder Land To Solder Land (LL)	0.075	0.075	0.075	0.075
Solder Mask Overlap (SO)	0.0625	0.0625	0.0625	0.0625
Solder Land Pitch (BL)	0.400	0.5	0.5	0.5
Line Width Between Via and Via Land (LW2)	N/A	0.1	0.1	0.1
Line Width Between Via out side Via Land (LW1)	0.127	0.127	0.127	0.127
Line to Via Land (LV)	N/A	0.050 - 0.100	0.050 - 0.100	0.050 - 0.100
Via Land Diameter (VL)	N/A	0.250 - 0.400	0.250 - 0.400	0.250 - 0.400
Through Hole Diameter (TH)	N/A	0.100 - 0.250	0.100 - 0.250	0.100 - 0.250
Die Attach Pad (DP)	2.920 x 2.920	4.700 x 4.700	5.700 x 5.700	6.300 x 6.300
Pad Array	Perimeter	Perimeter	Perimeter	Perimeter
Body Size	8x8	8x8	8x8	10x10
Periphery Rows	1	2	3	3

Note: *Component Land Pad and Solder Lands are rectangular, longest dimension is perpendicular to package edge.

PCB Land Pattern Design File

You can download the QN132 PCB Land Patter design file from Actel's website. This can be used to assist the layout of the board. Download the file from http://www.actel.com/documents/PCB_QN132_DF.zip.

List of Changes

The following table lists critical changes that were made in the current version of the document.

Previous Version	Changes in Current Version	Page
55700007-6/7.08*	Table 1a: Recommended PCB design guidelines for Actel CS (0.5 mm pitch BGA) package was updated to include uC36 data.	page 3
55700007-5/3.08*	Table 1a: Recommended PCB design guidelines for Actel CS (0.5 mm pitch BGA) package was updated to include uC81 data.	page 3
	Table 6: Recommended QFN Design Guidelines was updated to include QN68 data.	page 11
55700007-4/2.08*	Table 1a: Recommended PCB design guidelines for Actel CS (0.5 mm pitch BGA) package was updated to include CS201 and CS281.	page 3
	Figure 5:Suggested Board Layout of Soldered Pads for QFN Packages (PCB Bottom Layer) This Suggested board layout is for reduced thermal pad, NSMD, to use SMD swap SL and SM dimensions. is new.	page 10
	Figure 6:Suggested Board Layout of Soldered Pads for QFN Packages (PCB Bottom Layer), Reduced Thermal Pad is new.	page 11
	Table 6: Recommended QFN Design Guidelines was updated.	page 11

Note: *The part number is located on the last page of the document.

Actel is the leader in low-power and mixed-signal FPGAs and offers the most comprehensive portfolio of system and power management solutions. Power Matters. Learn more at www.actel.com.



Actel Corporation

2061 Stierlin Court
Mountain View, CA
94043-4655
USA
Phone 650.318.4200
Fax 650.318.4600

Actel Europe Ltd.

River Court, Meadows Business Park
Station Approach, Blackwtery
Camberley Surrey GU17 9AB
United Kingdom
Phone +44 (0) 1276 609 300
Fax +44 (0) 1276 607 540

Actel Japan

EXOS Ebisu Building 4F
1-24-14 Ebisu Shibuya-ku
Tokyo 150 Japan
Phone +81.03.3445.7671
Fax +81.03.3445.7668
<http://jp.actel.com>

Actel Hong Kong

Room 2107, China Resources Building
26 Harbour Road
Wanchai, Hong Kong
Phone +852 2185 6460
Fax +852 2185 6488
www.actel.com.cn

© 2009 Actel Corporation. All rights reserved. Actel and the Actel logo are trademarks of Actel Corporation. All other brand or product names are the property of their respective owners.