

---

# MicroTCA

---

## Introduction of MicroTCA and Actel Solution

Telecommunications computing architecture (TCA) standards are defined by the PCI Industrial Computer Manufacturers Group (PICMG<sup>®</sup>). AdvancedTCA (ATCA) is a 2002 PICMG standard that defines an architecture for high-performance, high-density, packet-based systems. In 2005, PICMG published the Advanced Mezzanine Card (AMC) specification, which extends ATCA's high-bandwidth, multi-protocol interface to hot-swappable modules, resulting in easy design, scaling, and servicing. In 2006, PICMG released the MicroTCA ( $\mu$ TCA) standard. MicroTCA is focused on a smaller form factor chassis to reduce the cost for lower bandwidth, high availability systems. Both ATCA and MicroTCA embrace the Intelligent Platform Management Interface (IPMI) protocol, introduced for server blades by Intel in 1995 and then expanded to board- and system-level management applications. ATCA and MicroTCA are architected so that the AMC is compatible and interchangeable between the two systems.

Based on Actel Fusion<sup>™</sup> devices, the latest Flash-based, mixed-signal FPGA technology, Actel is developing a fully compliant MicroTCA management solution by delivering complete hardware, software, and IP platform reference designs for the basic MicroTCA management elements for the Advanced Mezzanine Card (MC), Power Module (PM), MicroTCA Carrier Hub (MCH), and Cooling Unit (CU). The goal is to provide customers with solutions that are modular, compact, and low cost, and easy to customize, maintain, and re-use.

This document covers the general concept of the MicroTCA specification, and highlights the benefits of Actel MicroTCA management solutions.

## Overview of MicroTCA Specifications

### General Overview

The primary focus of MicroTCA is to provide a mechanical and electrical platform for telecommunications and enterprise computer network equipment. A minimum MicroTCA system consists of the following elements:

- At least one and up to four power modules (PMs)
- At least one and up to two MicroTCA Carrier Hub (MCH) cards
- At least one and up to twelve AMC I/O cards
- At least one and up to two cooling units (CUs)
- Mechanical resources needed to support all above elements

MicroTCA defines the basic elements that are capable of powering and managing the AMCs at high efficiency and low cost. [Figure 1 on page 2](#) and [Figure 2 on page 3](#) show MicroTCA block diagrams.

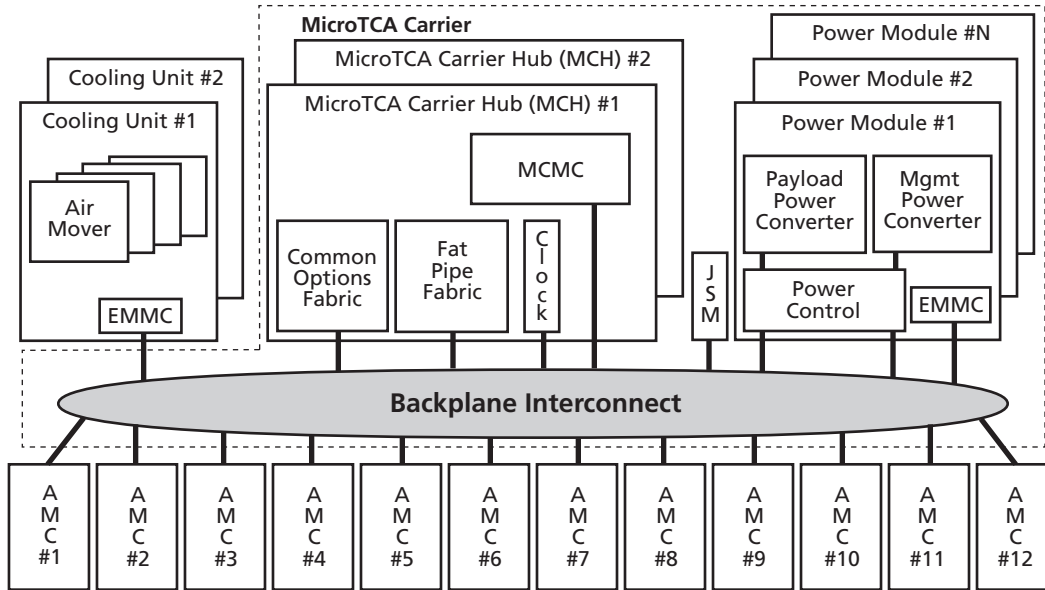

Figure 1 • MicroTCA Block Diagram

The PICMG MicroTCA specification was written with the following design goals in mind for the payload:

- Complementary to AdvancedTCA
- Full conformance with the AMC.0 module definition
- Standardized shelf management compatible with AdvancedTCA
- Favorable cost, size, and modularity
- Low start-up costs
- Scalable backplane bandwidth
- Backplane bandwidth: SerDes at 1–12 or more Gb/s
- Backplane topologies: Star, Dual Star, and Mesh
- Modular and serviceable
- Support 300 mm nominal equipment depth and 19 in. nominal equipment width
- Power: 12 V to AdvancedMCs, in conformance with AMC.0
- Cooling: 20–80 W per AdvancedMC
- Support for extended temperatures (–40 to +65°C)
- Scalable system reliability: From 0.999 to 0.99999
- Hot -swap/plug-and-play support, in conformance with AMC.0 and AdvancedTCA

The MicroTCA specification calls for a host of system management functionality in the MCH, the PM, and the CU. The MicroTCA Carrier Hub modules are used to monitor the performance of the payload and communicate or control any deviations from expectations. Often, the system will have a remote supervisor that communicates with the MCH. Remote supervision is one of the exceptional features of the specification. The MCH provides the carrier and shelf management functions; these are similar to the functions of a baseboard management controller and network management controller per the IPMI specification. The MCH will monitor and control the chassis and the subsystems via the IPMB-0 and IPMB-L communication interfaces (part of the EMMC and MMC, respectively).

The IPMB-0 interfaces connect to the power modules and cooling units. The power module will supply power to the rest of the chassis. Typically, there is a –48 V input with 12 V and 3.3 V output for the power module. The 12 V output is known as the payload power and the 3.3 V output is known as the management power. The PM requires a significant number of analog I/Os for power and thermal

monitoring and controlling. The cooling unit keeps the elements of the chassis cool with a number of fans. Again, a significant number of analog I/Os are required to monitor and operate the fans.

Finally, the IPMB-L connections link the MCH to the AMCs. AMCs have management and payload portions of the design and are the modules in the chassis that are performing the key applications, such as a processor card, an I/O card, or a storage card.

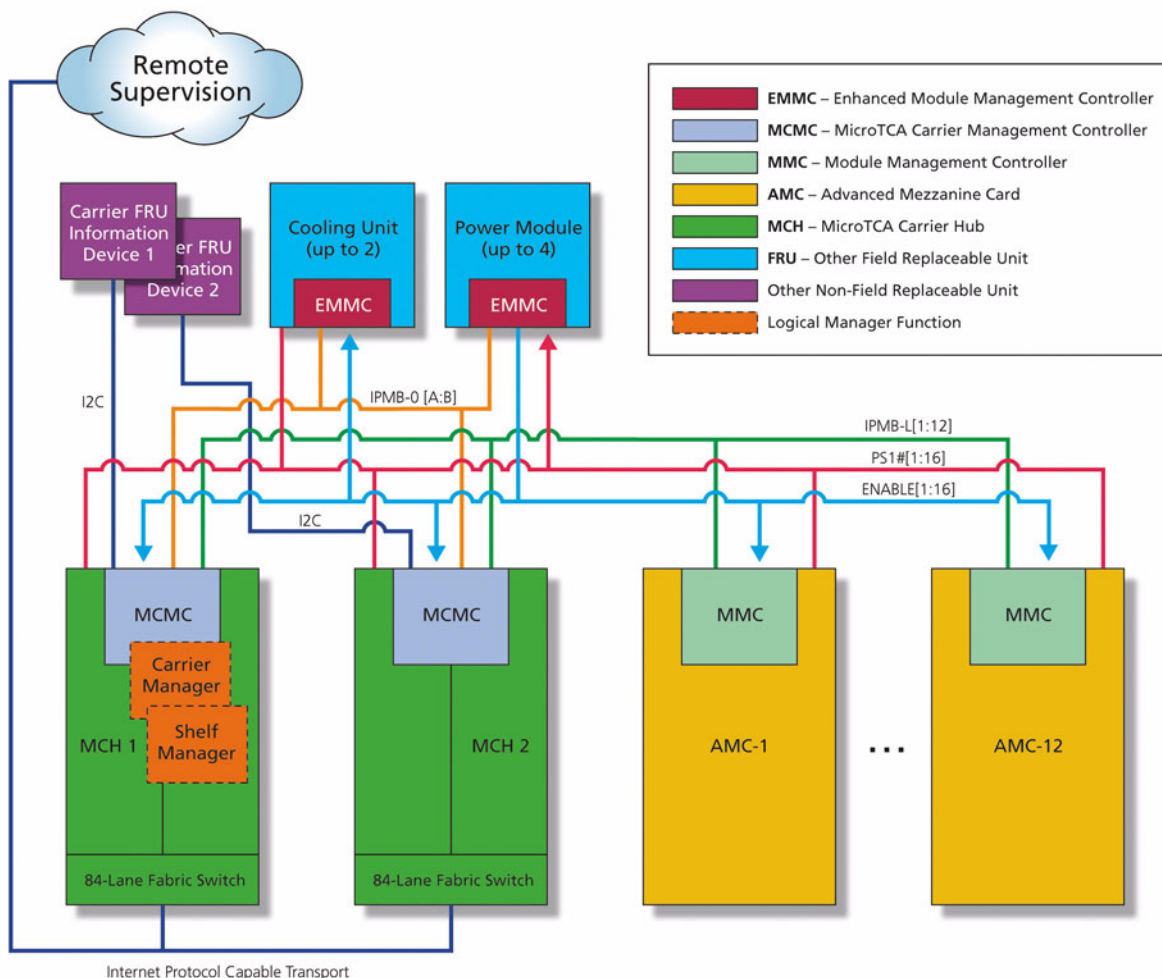

Figure 2 • Management Aspects of an Example MicroTCA Shelf

## Overview of Actel Solution

The Actel Fusion FPGA is an ideal platform for system management in a MicroTCA module. Actel supports Fusion-based MMC and EMMC solutions with fully coded reference designs. Each reference design includes an embedded processor and interface intellectual property (IP) cores, IPMI software, and customization services. The nature of the reference designs enables quicker time to market, reduced risk, and low costs, as well as improved performance and advanced functionality, improved reliability, and high availability.

This revolutionary support is intended to help our customers use the reference design as is or as a starter to customize their own designs. While the MicroTCA standard is intended to reduce the cost of telecommunications and data networking systems, it may also propel new architectures and innovations in industrial, medical, and military equipment. Similar to replacement of the mini-computer by the

personal computer, a variety of electronic systems will benefit from targeting a modular, low cost, high availability MicroTCA chassis.

To demonstrate that Fusion devices can perform as a platform for MMC and EMMC solutions, Actel has created turn-key reference designs for a MicroTCA PM and an AMC. The MicroTCA PM reference design includes Verilog code for the FPGA design, ANSI-C code for an embedded 8051 processing core (including routines to support the necessary IPMI protocol), module level schematics and layout files, and the associated bill-of-materials. This document currently discusses the PM, and will be updated for future reference design releases.

## MicroTCA Power Subsystem

Figure 3 shows the MicroTCA Power Subsystem.

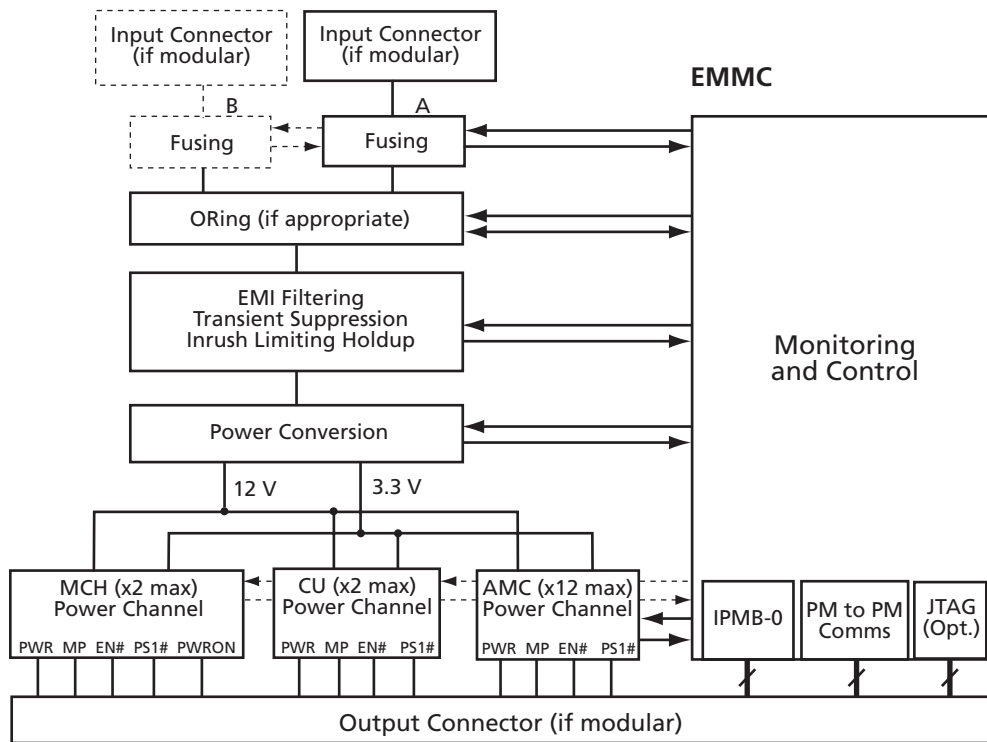

Figure 3 • MicroTCA Power Subsystem

A MicroTCA power module provides the following functionality:

- Input power monitoring and selection
- Power conversion
- Independent payload and management power distribution and monitoring
- Control interface to MCH for status and distribution control (IPMI)
- Circuit protection and time-critical switchover
- Optional power module redundancy
- Optional support for JTAG-based, in-system test and upgrade

The monitoring and control functions of the power module are done by the Enhanced Module Management Controller (EMMC). It provides the following:

- Voltage measurement
- Current measurement
- Temperature Monitor
- Power sequencing
- FRU ROM support
- Dual I2C/IPMI interface

Distinguished from other power modules in the market, the Actel power module solution, shown in [Figure 4 on page 6](#), provides full-featured support, as defined by MicroTCA specifications.

- Input Power ORing
  - Supports dual DC power inputs from –36 V to –72 V
  - Includes isolated input voltage monitoring and selection
  - Includes EMC Filtering and energy storage for hold-up requirements
- Power Conversion
  - Provides 12 V payload power up to 384 W
  - Provides 3.3 V  $\pm 10\%$  management power
- Independent payload and management power distribution
  - 16 individually managed/monitored payload power channels
    - Voltage monitoring with globally settable "over/under" thresholds
    - Current monitoring with per channel settable "over" thresholds
    - Inrush current limiting and channel ORing
    - Automatic redundancy switchover control circuits
  - 16 individual management power channels
    - Voltage monitoring with fixed over/under thresholds
    - Automatic current limiting (fixed range)
    - Automatic redundancy switchover control circuits
- Control Interface to MicroTCA Carrier Hub(s)
  - Dual IPMB-0 serial interfaces
  - Embedded 8051 processor core and associated IPMI software
  - 512 kbytes nonvolatile memory (NVM) for SEL and SDR record storage
  - Built-in watchdog timer / service life counter
- Optional system interfaces
  - Optional JTAG interface to JSM
    - Supports device boundary scan, in-system FPGA programming, and remote upload of processor firmware via JTAG
  - Optional front-panel USB interface
    - Uses standard USB port to emulate an RS-232 link to the EMMC
    - Software can be configured to interact with this port

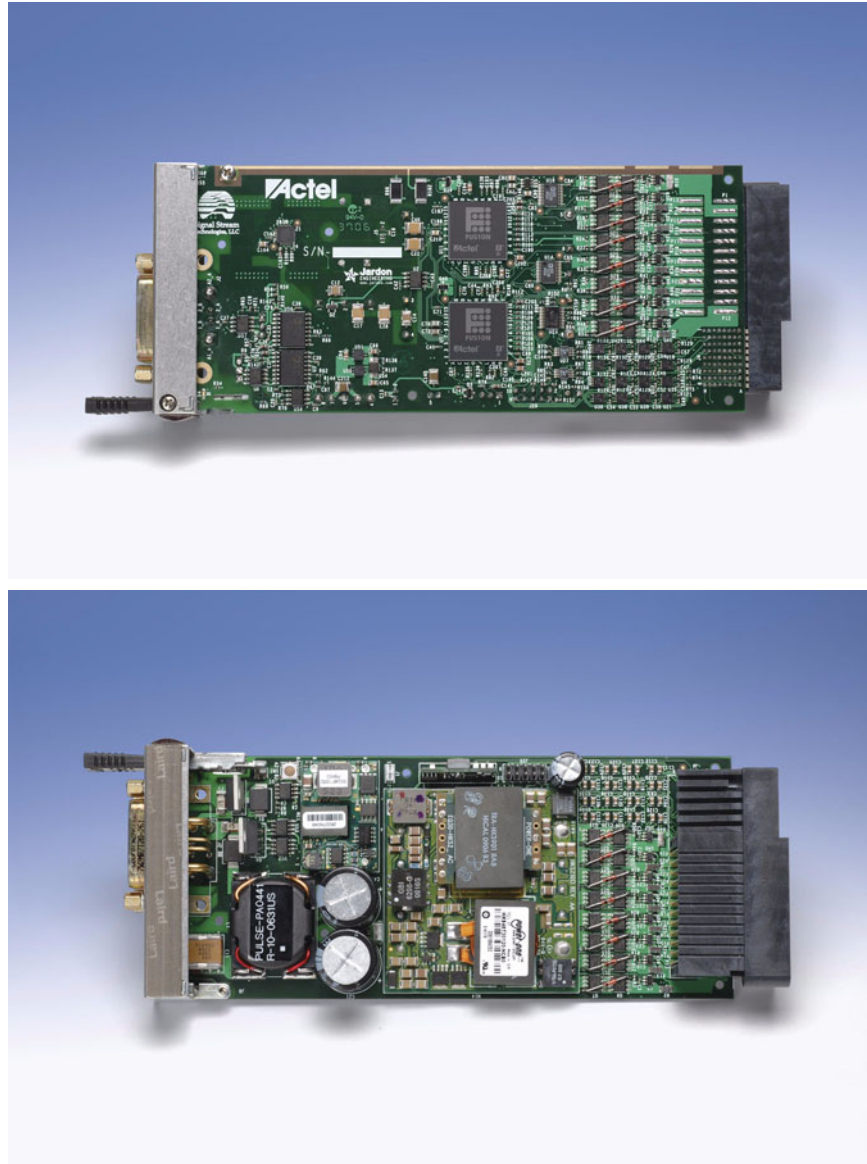

Figure 4 • Actel Power Module Reference Design

The Actel power module solution utilizes the world's first mixed-signal, Flash-based FPGA—the Actel Fusion Programmable System Chip (PSC).

The Actel Fusion device is an excellent single-chip solution for system management applications. As a Flash-based FPGA, the Fusion PSC is live at power-up. Unlike any other FPGA, Fusion includes a configurable analog subsystem to sample and monitor up to 30 channels of analog signals and control up to 10 gate drivers with programmable drive strengths that control sequencing and ramp-rates of multiple power supplies.

Integrated embedded Flash memory enables a wide variety of tasks: recording system performance history, updating operating parameters, monitoring system parameters to predict failures before they occur (prognostics), EEPROM emulation, and boot code storage. The embedded Flash can be read or updated from the standard JTAG ports or from a user interface in the FPGA fabric while the device is operating. With an internal voltage regulator to generate the 1.5 V core voltage, Fusion PSCs require only a single 3.3 V power supply. While the Flash process provides Fusion with low static and dynamic power consumption, the user can easily implement low power standby and sleep operation modes by using the

internal voltage regulator for further power savings. The internal real-time counter (standby) or an external signal (standby and sleep) can wake up a Fusion device.

## Actel Power Module Implementation and Benefits

Two Actel Fusion (AF5600) devices are used in the Actel MicroTCA power module to perform EMMC functions. The EMMC directly supports the following:

- 36 voltage measurements
- 16 current measurements
- 3 temperature monitors
- Power channel control
- Hardwired circuit protection
- Dual IPMB-0 Interfaces (I2C)
- IPMI commands, including FRU ROM and optional SEL/SDR

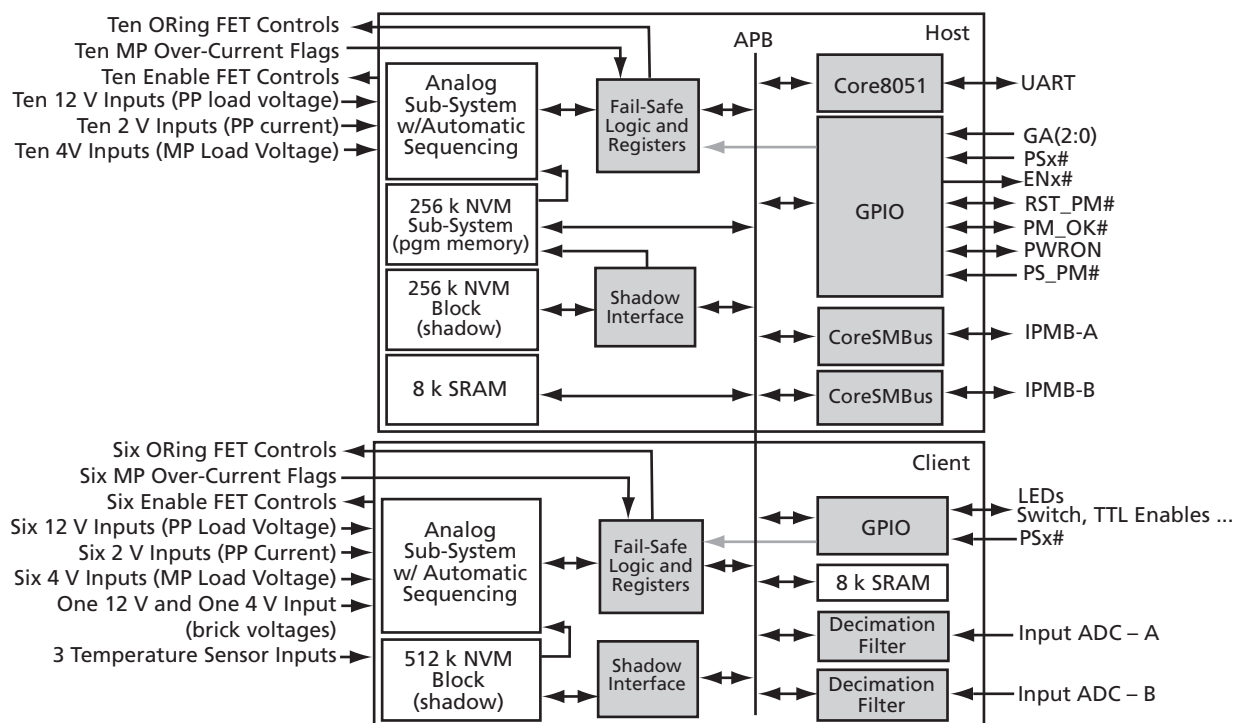

Figure 5 • Block Diagram of Power Module EMMC Block Implemented in Fusion

The Actel EMMC design is a highly integrated solution that resolves many engineering problems in a power module design. These include challenges such as high analog/digital I/O counts, 100  $\mu$ s response time requirements for fail-safe and switchover circuits, congested board layout with many discrete components, and remote in-system upgrade capability.

## I/O Utilization

The Actel EMMC, based on Fusion, monitors over 53 analog inputs, including 36 voltages, 16 currents, and 3 temperatures. With internal analog, MUX, and voltage prescalers, Fusion can handle multiple channels of high-voltage or low voltage inputs, without external ADCs, MUXes, or input scaling.

Even high-end microcontrollers do not have this many analog I/Os. In this case, external ADC/MUX functions or multiple microcontrollers are required, which splits the "code-base" into multiple "programs" that must interact with each other. Likewise, most microcontrollers do not have built-in voltage scaling circuitry requiring many extra components on the power module. Additionally, microcontrollers do not have enough analog inputs to include direct current measurements, which precludes or significantly limits threshold programmability. Most microcontrollers do not directly measure temperature; they require extra external devices.

Similarly, most microcontrollers and other FPGA devices do not have integrated MOSFET drivers to directly control the power channels. Fusion does include integrated analog gate (AG) driver pins that provide slow turn-on and fast turn-off to the payload power channels.

The EMMC also utilizes over 140 digital and analog inputs and outputs:

- 11 input power and brick monitoring/control signals
- 16 MP (management power) over current flags, 16 MP enables
- 32 PP (payload power) FET controls
- 32 AMC interface signals, 12 PM redundancy and GA pins
- 16 serial interface pins (IPMB-A, IPMB-B, ADC-1, ADC-2, UART, JTAG)
- 8 discrete GPIO (LEDs, switches, etc.)

Fusion definitely has advantages here. Microcontrollers just do not have the large number of GPIO pins that are required.

## Fail-Safe

One of the functions of the EMMC is to monitor the voltage and current of each power channel and ensure that the channel is functioning within desired voltage and current limits. In the event of a card removal or an over-voltage or over-current violation, the channel must be disabled to prevent damage to the system.

A microcontroller-based EMMC solution would have to constantly poll the status of each slot in order to react to any power-channel failure. The software implementation involves high cost to "throughput." If a payload power supply failure occurs right after the microcontroller has polled its status, no action will be taken until the microprocessor polls the channel status again. These "fail-safe" features can fail if software runs too slow or encounters an error. The slow or incorrect response could permanently damage the payload and related circuits in the MicroTCA shelf.

Because it is an FPGA, the hardwired fail-safe circuitry in Fusion immediately responds to any card removal or voltage, current, or temperature threshold violation; it thereby achieves 100  $\mu$ s power-channel disable/switchover, as defined in MicroTCA specifications. These actions occur independently of software control, so your Fusion-based power module is safe by design, regardless of software state and system loading. FPGA gates can disconnect power supplies to dysfunctional payloads almost immediately to protect the power module, backplane, and payload. At the same time, the logic generates a flag to inform the embedded software, which in turn can signal an event to the MCH and/or higher-level management layer. The Fusion hardware fail-safe implementation ensures safety and provides superior visibility and reliability, while freeing up software MIPS for IPMI operations and simplifying software development and maintenance.

FPGA gates are also useful for hardwired coprocessing functions. For example, an autonomous SPI interface accesses data from the isolated input power ADCs, reconstructs the sample data, and performs the necessary filtering functions to offload the software. These functions are unlikely to change, and therefore are ideal for implementation as hardware. With the Fusion reprogrammable FPGA fabric, they can be updated if necessary.

In addition to the fail-safe control functions and input power ADC filtering, the Actel EMMC design also leverages hardwired co-processing functions for the I2C interfaces, boot-loader functions, and other well-defined low-level operations.

## Power Module Redundancy

By meeting the MicroTCA power module redundancy requirements, the Actel power module solution can interact with up to four independent power modules in a single MicroTCA shelf. Each power module can be configured to serve as the primary or backup supply for a given power channel via IPMI commands. Once enabled, a primary power module will automatically disable its power channel whenever a card is removed, or in the event of an over-voltage, over-current, or under-voltage condition. Likewise, once a power module is enabled to serve as backup for a given power channel, the module will monitor the voltage on the channel and automatically enable itself when a card is present and the channel voltage drops below the specified cut-in voltage. Once enabled, the secondary supply will behave as a primary power module for this channel until directed otherwise via IPMI command. With this fail-safe redundancy feature, redundant Fusion-based power modules can achieve 0.99999 reliability, or less than 316 seconds down time per year.

## Part Count

The Actel Fusion-based power module is a clean and economic solution. It needs only one double-side PCB and includes less than 400 components. The layout is elegant and takes into consideration all of the unique requirements endemic to a high density power solution. With plenty of room for layout, the design was easily arranged to isolate noisy digital components on one side of the board, while sensitive high-current power circuits were placed on the opposite side. Other solutions need two double-side PCBs to pack in more than 1,000 discreet components, and power conversion circuits are forced to co-exist with digital elements in close proximity. In addition to the obvious parts count/cost differences, the highly integrated Actel reference design has many indirect advantages. It contains only 65 unique items to stock, which reduces purchasing, stocking, and kitting costs. With only a single base printed circuit board and fewer than 400 components, assembly and inspection costs are greatly reduced, while module thermal characteristics and overall reliability are improved.

## Software Development and Maintenance

In addition to the board-level design and FPGA implementation, Actel offers a complete software solution with the Power Module reference design. An embedded 8051 processor core is the heart of the Fusion EMMC solution, and while a customer may choose to develop and maintain their own control software, Actel also provides a complete ANSI-C code base targeted for the EMMC. This code base includes all of the basic control functions and IPMI command processing necessary for a MicroTCA power module.

Unlike microcontroller solutions that require more than one processor, and therefore multiple code bases that interact, the Fusion EMMC design supports a single processing point. Many of the mundane or time-critical functions are implemented in hardwired gates, so software development and maintenance is simplified and IPMI throughput is maximized.

## Engagement Models

Actel supports a variety of engagement models that allow each customer great flexibility for supporting their final power module design. Actel power modules are available for evaluation in the customer's MicroTCA environment. Once engaged with Actel, a customer can choose to use the power module hardware "as-is," customize the module, or work with an Actel partner to create a unique power module design powered by Fusion. Likewise, a customer can choose to use the Actel IPMI code base "as-is," or use it as a starting point for writing custom control routines and supporting additional IPMI commands that are otherwise optional under the MicroTCA specification. Again, software development support and maintenance contracts are available through the Actel partner program, giving Actel customers a range of engagement models to suit all needs.

## ISP Solution

The Actel Power Module reference design provides a total of one megabyte of Flash memory embedded in the Fusion devices. Half of this memory is partitioned for use as the 8051's program code and nonvolatile data storage. A boot-loader is incorporated to support two 256 kbyte memory images: one for "active program memory" and the other for "update image" storage. The other 512 kbytes are available to user-modified software as nonvolatile storage for a system event log (SEL), sensor data record repository (SDR), or proprietary data storage.

To access these memory spaces, the Actel EMMC reference design supports JTAG access to Flash memory and FPGA fabric through the MicroTCA JSM facility, and indirect Flash memory access through the USB/UART interface on the front panel. The Actel code base includes a boot-loader function that allows access to the "upload image" using a simple protocol via an USB/RS-232 port on a PC.

In comparison, many microcontrollers do not support a JTAG interface at all, and cannot provide in-system remote hardware upgrade capability. Neither do they have enough embedded Flash memory to support online software updates in addition to sensor data and event logging functions.

## Other MicroTCA Solutions from Actel

The Actel Power Module reference design demonstrates that Fusion is an ideal choice for EMMC and MicroTCA system management implementations. Building on the power module, Actel will also provide an Advanced Mezzanine Card solution (MMC), a cooling unit solution (EMMC-II), and a Carrier Hub solution (MCMC).

## Summary

Using Actel Fusion devices as the core of the MicroTCA power module design drastically reduces component count on the board, simplifies the assembly process, and thus reduces overall cost. The power module redundancy feature boosts system reliability to .99999. The modularized design approach allows customers to take the Actel power module design and software and easily customize it to meet their unique requirements. Platform similarity among the MicroTCA basic elements also gives customers the opportunity to port the power module EMMC design into cooling unit designs and AdvancedMC designs, with appropriate hardware or software changes. The Actel MicroTCA power module solution is fully compliant to MicroTCA specifications and greatly reduces product development effort.

## References

PICMG website: <http://www.picmg.com/>

MicroTCA Specification: <http://www.picmg.org/v2internal/microTCA.htm>

ATCA Specification: <http://www.picmg.org/v2internal/newinitiative.htm>

Actel and the Actel logo are registered trademarks of Actel Corporation.  
All other trademarks are the property of their owners.



[www.actel.com](http://www.actel.com)

**Actel Corporation**

2061 Stierlin Court  
Mountain View, CA  
94043-4655 USA

**Phone** 650.318.4200

**Fax** 650.318.4600

**Actel Europe Ltd.**

River Court, Meadows Business Park  
Station Approach, Blackwater  
Camberley, Surrey GU17 9AB  
United Kingdom

**Phone** +44 (0) 1276 609 300

**Fax** +44 (0) 1276 607 540

**Actel Japan**

EXOS Ebisu Bldg. 4F  
1-24-14 Ebisu Shibuya-ku  
Tokyo 150 Japan

**Phone** +81.03.3445.7671

**Fax** +81.03.3445.7668

[www.jp.actel.com](http://www.jp.actel.com)

**Actel Hong Kong**

Suite 2114, Two Pacific Place  
88 Queensway, Admiralty  
Hong Kong

**Phone** +852 2185 6460

**Fax** +852 2185 6488

[www.actel.com.cn](http://www.actel.com.cn)