

Built-In Software-Based Calibration Option in Programmable System Chips

Many of today's intelligent system management designs must constantly monitor several voltage rails and take appropriate action when certain conditions exist. For this reason, these applications need accuracy levels better than one percent. When such a need exists, the accuracy offered by most analog-to-digital converters (ADCs) is not sufficient.

In principle, the operation of an ADC is very simple. Given an analog input, it provides an accurate output value in digital format. However, in reality, the accuracy of the output voltage is subject to a number of factors, including gain and offset errors from the ADC and from other components.

To manage growing noise and interference and to achieve the stringent accuracy and precision levels required by intelligent system management and industrial control applications, multiple discrete components, such as a prescaler or a divider network, have traditionally been used to meet different application requirements. However, this increases power consumption, noise, and cost.

These discrete solutions can offer high levels of accuracy, but lack features and do not offer an expansion path. Further, discrete solutions may offer a specific input voltage range with a single polarity or limited number of input channels, forcing the designer to use multiple components to realize his design goals.

The best scenario is the availability of a feature-rich, mixed-signal programmable system chip (PSC) capable of supporting a calibration scheme, both in software and without the use of external components, to enable easier design implementation, improve accuracy, lower overall power consumption, and increase signal integrity.

Calibration

Calibration eliminates certain errors common to ADCs, such as offset and gain errors. Offset error is the deviation from the minimum voltage expected when the minimum code is applied. On the other hand, gain error is the deviation in the slope of the transfer function when the offset error is removed from the ideal. If these errors are not adjusted, the measurements would be inaccurate and could impact the overall system performance.

A one-point calibration scheme is commonly used to eliminate offset errors. A constant correction is applied to the measured data and provides the corrected data. Even though this method is simple, it does not address gain errors. Alternatively, a two-point calibration scheme measures the gain coefficients at two points along a straight-line fit. A straight-line fit using $Y = Mx + C$ is computed, where M is the gain error (that is, the slope of the straight line), C is the offset error, x is the measured value, and Y is the corrected value. If the M and C coefficients are stored in memory and retrieved by a software solution that includes a soft IP to compute the correction for each measurement, they can be used to eliminate the gain and offset errors to achieve higher overall accuracy.

Seamless Calibration Using PSCs

Today's PSCs include FPGA fabric, embedded flash, and SRAM blocks, as well as analog functions, such as real-time clock (RTC), ADCs, FET gate driver output, and current, voltage, and temperature monitoring blocks (Figure 1). These highly integrated programmable solutions, such as Actel Fusion™ PSCs, also support the use of a variety of industry-standard processor cores, such as 8051 and ARM,® making them compelling for system management, intelligent power management, and embedded control applications. One of the blocks within the PSC is a prescaler circuit that can be used in conjunction with the ADC for monitoring voltage and temperature functions, for example. In a real-time monitoring application, the function being monitored may not provide a measurement within the required accuracy. As a result, a prescaler range needs to be selected to provide the best accuracy. Each prescaler has multiple scaling factors programmed by FPGA signals to support a large range of analog inputs with positive or negative polarity. The prescaler circuit scales the voltage applied to the ADC input pad in a manner that makes it compatible with the ADC input voltage range.

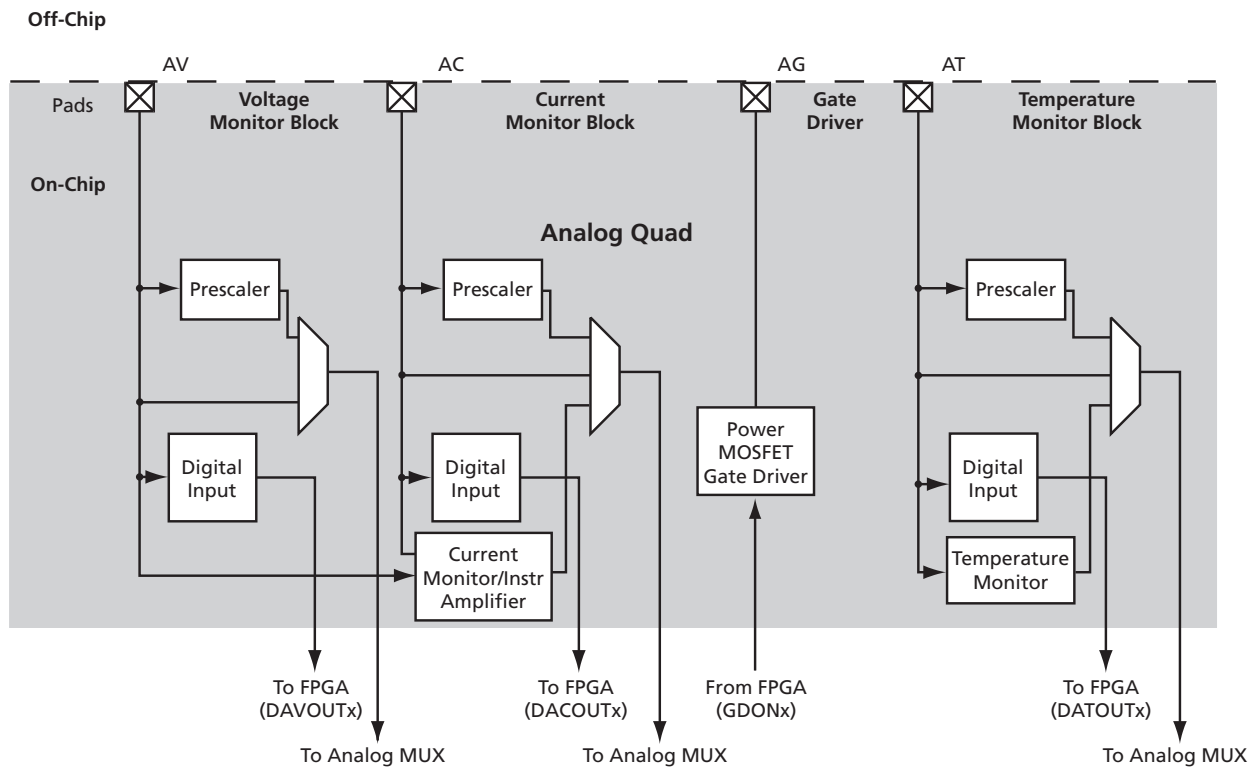

Figure 1: Analog Quad

When the voltage being monitored is small compared to the chosen prescaler range, the accuracy may not be as good as a smaller range that is closer to the voltage being monitored. For example, when monitoring 3.3 V, the choice of prescaler range defines the accuracy that can be achieved. Choosing a 16 V or 8 V range will not deliver accuracy levels as high as when using the 4 V prescaler range. The choice of the prescaler range plays a critical role in defining the accuracy a customer can expect for his application. Similarly, if the V_{REF} voltage of the ADC is selected to be 2.56 V, for example, Actel recommends that no prescalers be used and the direct input to the ADC be used, which can deliver much higher accuracy than using prescalers, making calibration unnecessary.

Generally, PSCs are designed to a specific accuracy target, but an additional calibration option can be made available for customers who require higher accuracy levels. A software-based calibration option utilizes eNVM or flash memory blocks to store offset and gain coefficients, a calibration intellectual property (IP) core made of logic gates to implement the calibration solution, and SRAM memory blocks to process the data. Combined with the integration benefits offered by mixed-signal Fusion PSCs, the easy-to-use calibration option offers customers greater accuracy, lower system power, reduced design complexity, flexibility, and more features than those offered by most discrete solutions.

During manufacturing testing, the offset and gain coefficients are preloaded and stored in the device. Therefore, upon receipt of the device, if the customer chooses to apply calibration, the calibration IP engine retrieves the coefficients, computes the M and C for every measurement, and applies the appropriate correction. The design flow is completely supported within the PSC design flow, requiring the customer to have no prior calibration experience. Overall, the easy-to-use software-based calibration option enables customers to achieve better signal integrity and overall noise reduction.

An additional advantage of this PSC built-in calibration support is the ability to calibrate the device in the field. Boards exposed to differing environments over time can accumulate noise and the readings can drift. Generally, these boards and devices need to be calibrated to mitigate some of these noise issues. Due to the programmability and the embedded memory features of the Fusion PSC device, customers have the option of implementing their own calibration further along in the life cycle of the product. Alternatively, if a customer were to attempt to recalibrate a discrete component in the field, it might involve measurements in the field and recalibrating the unit using external components, adding to the overall system cost without providing an easy option for upgrade.

An Example—Calibration Can Provide the Desired Result

Customers who opt to use the calibration option in the Fusion PSC can obtain very compelling results. [Table 1](#) and [Table 2](#) on page 4 highlight accuracy levels without calibration and with calibration using the two-point 20–80% calibration scheme. [Figure 2](#) shows that by computing the value at 20% and 80% of the ACD Count versus Input Voltage graph, the gain can be then be computed and used as the M , or gain coefficient, in computing the error contributed by the gain of the system.

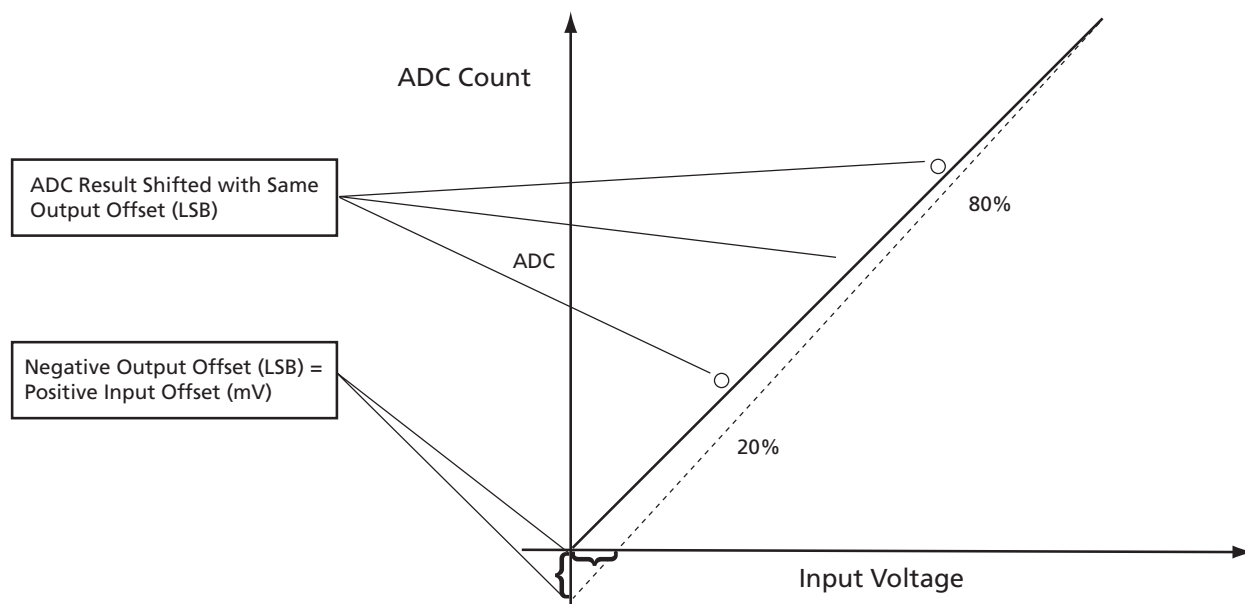

Figure 2: 20% – 80% Calibration Scheme

Table 1: Accuracy without Calibration

Voltage Being Monitored	16 VP	8 VP	4 VP
12 V	1.47%		
5 V	2.56%	2.72%	
3.3 V	3.88%	3.88%	3.52%
2.5 V	5.76%	4.48%	4.48%

Table 2: Accuracy with Calibration

Voltage Being Monitored	16 VP	8 VP	4 VP
12 V	0.53%		
5 V	1.28%	0.48%	
3.3 V	1.45%	0.73%	0.61%
2.5 V	1.92%	0.96%	0.48%

As demonstrated in [Table 1](#) and [Table 2](#), with the selection of an appropriate prescaler range for a specific monitored voltage and the correct calibration option, customers can obtain accuracy better than one percent. This high level of accuracy will go a long way in mitigating general board-level noise issues.

Calculating Calibrated Output for an Uncalibrated Analog Channel

For a given prescaler range, the output voltage is computed as follows:

Output voltage or $Y = (\text{Channel Output Offset in Volts or } C) + (\text{Input Voltage or } x \times \text{Channel Gain Factor or } M)$, where

Channel Output Offset in Volts = Channel Output Offset in terms of LSB \times Equivalent Voltage per LSB and

Channel Gain Factor = $1 + (\% \text{ Channel Gain}/100)$. Note that Channel Gain can be negative.

As an example, assume the customer would like to monitor a 5 V voltage using an 8 V prescaler range. The maximum output voltage can be determined as follows:

Maximum Output Voltage = (Maximum Positive Output Offset) + (Input Voltage \times Maximum Gain Factor)

Maximum Positive Output Voltage = (8 LSB as determined by test) \times (8 mV per LSB in 10-bit mode)

Maximum Positive Output Offset = (8 LSB) \times (8 mV per LSB in 10-bit mode as per the accuracy table specified in the Fusion datasheet) = 64 mV

Maximum Gain Factor = $1 + (1.02/100) = 1.0103$

Maximum Output Voltage = (64 mV) + (5 V \times 1.0102) = 5.115 V

Calculating Output for a Calibrated Analog Channel

For a given prescaler range, the output voltage is derived as follows:

TUE is defined as the total unadjusted error for the ADC.

Output Voltage = Channel TUE in Volts + Input Voltage.

The TUE can be calculated as follows for a given Fusion device:

Channel TUE in Volts = Channel TUE in LSBs × Equivalent Voltage per LSB.

If the customer is monitoring a 5 V power supply using an 8 V prescaler range, the maximum output voltage is computed as follows:

Maximum Output Voltage = Maximum Channel TUE in Volts + Input Voltage

Maximum Channel TUE in Volts = (6 LSB) × (8 mV per LSB in 10-bit mode) = 48 mV

The maximum channel TUE in LSBs is specified in the Fusion datasheet and the equivalent voltage per LSB is based on the resolution of the ADC. Once the maximum channel TUE in volts has been computed, the maximum output voltage is then deduced as follows:

Maximum Output Voltage = 48 mV, which is the Maximum Channel TUE in Volts + 5, which is the Input Voltage, for a total of 5.048 V.

Conclusion

The high accuracy requirements of system management applications can be achieved by using external discrete components, but at the expense of incremental design complexity and lower signal integrity. To meet the required accuracy, a highly integrated programmable system chip with an easy-to-use, built-in, software-based calibration option enables customers to achieve overall noise reduction and accuracy better than one percent. Overall, combined with the integration benefits offered by mixed-signal Fusion PSCs, the easy-to-use calibration option offers customers greater accuracy, lower system power, reduced design complexity, and flexibility, with significantly lower system cost and more features than those offered by most discrete solutions.

For more information, visit our website at www.actel.com



Actel Corporation
2061 Stierlin Court
Mountain View, CA
94043-4655
USA
Phone 650.318.4200
Fax 650.318.4600

Actel Europe Ltd.
River Court, Meadows Business Park
Station Approach, Blackwtery
Camberley Surrey GU17 9AB
United Kingdom
Phone +44 (0) 1276 609 300
Fax +44 (0) 1276 607 540

Actel Japan
EXOS Ebisu Building 4F
1-24-14 Ebisu Shibuya-ku
Tokyo 150 Japan
Phone +81.03.3445.7671
Fax +81.03.3445.7668
<http://jp.actel.com>

Actel Hong Kong
Room 2107, China Resources Building
26 Harbour Road
Wanchai, Hong Kong
Phone +852 2185 6460
Fax +852 2185 6488
www.actel.com.cn

© 2008 Actel Corporation. All rights reserved. Actel and the Actel logo are trademarks of Actel Corporation. All other brand or product names are the property of their respective owners.

55900081-0/3.08

