

AGLP125 IGLOO PLUS Board

DVP-100-000271-001 RevB

| PAGE NO | TITLE |
|---------|--------------------------|
| 01 | TITLE BLOCK |
| 02 | POWER SUPPLY 1 |
| 03 | POWER SUPPLY 2 |
| 04 | AGLP125 DEVICES - CSG289 |
| 05 | AGLP125 DEVICES & DECAPS |
| 06 | SWITCHES&LEDS |
| 07 | USB TO UART |
| 08 | FLASH FREEZE VARIANTS |

| | | |
|---------------------------------|--------------------------|--------------|
| Actel | | |
| Title | | |
| DVP-100-000271-001 Rev B | | |
| Size | Document Number | Rev |
| B | TITLE PAGE | B |
| Date: | Friday, October 31, 2008 | Sheet 1 of 8 |

USB ACTIVE IN RUSH LIMITER

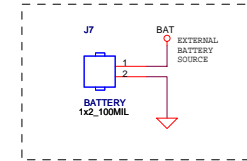
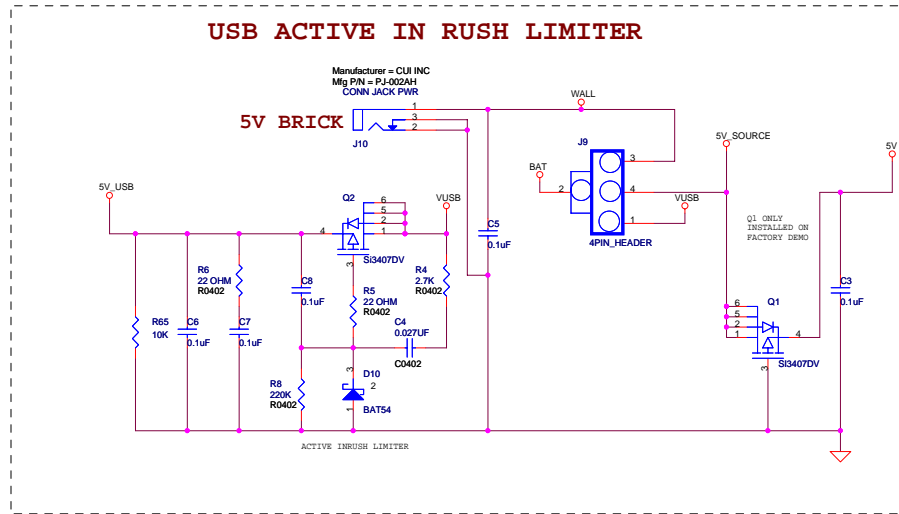

10V SUPPLY WITH TRUE SHUTDOWN

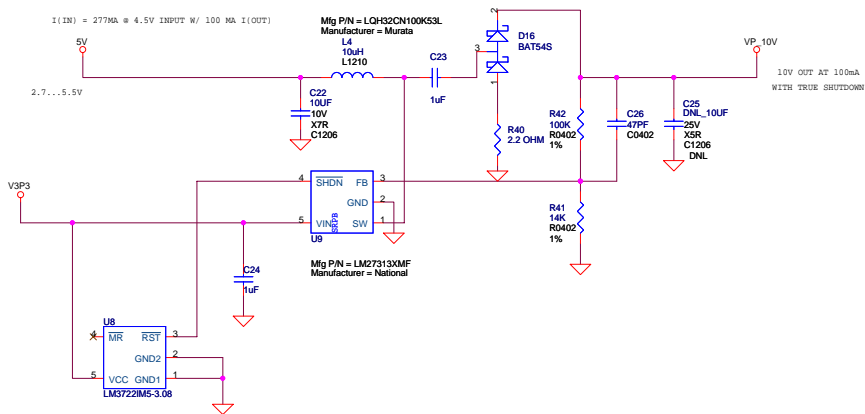

DC IN TO 3.3V AT 4A

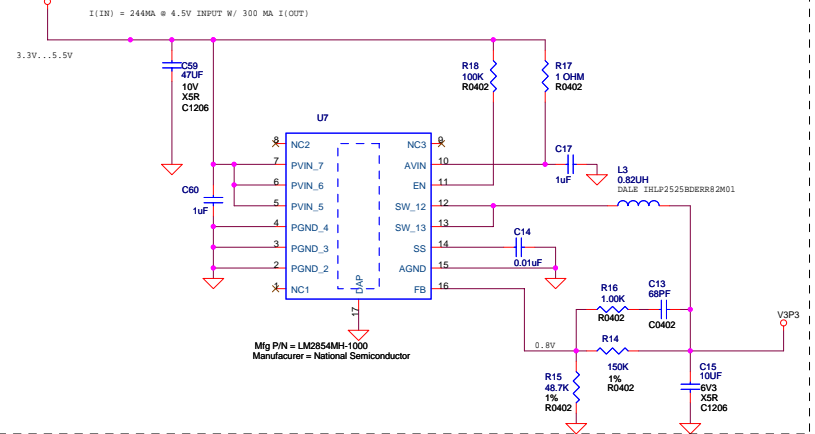

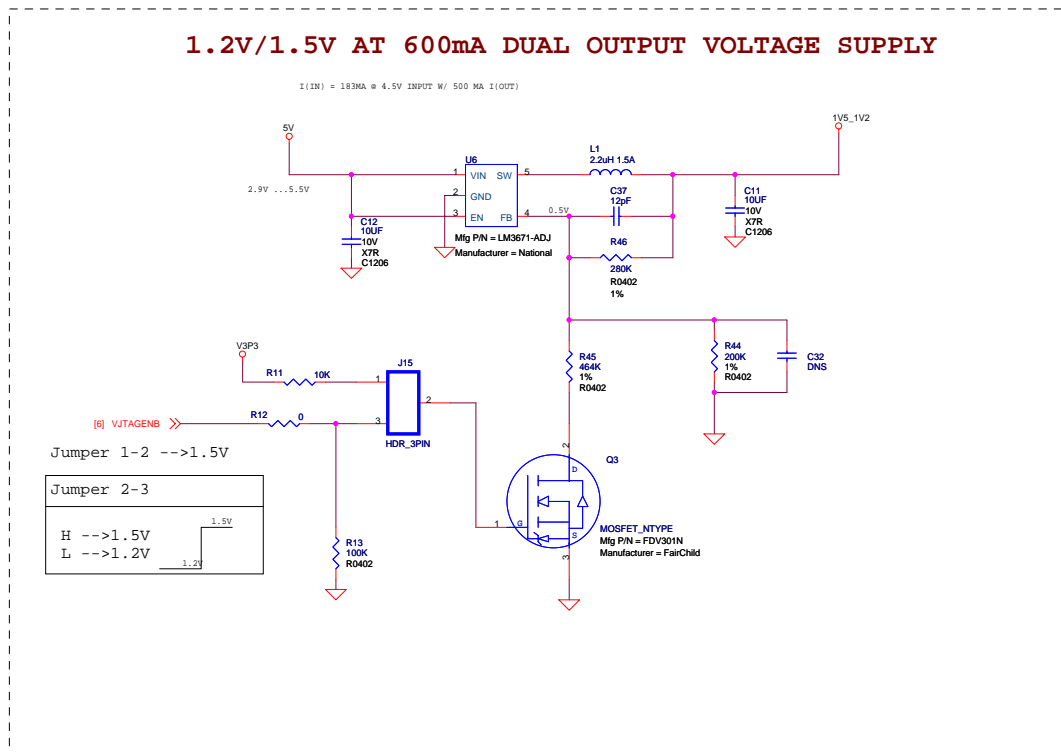
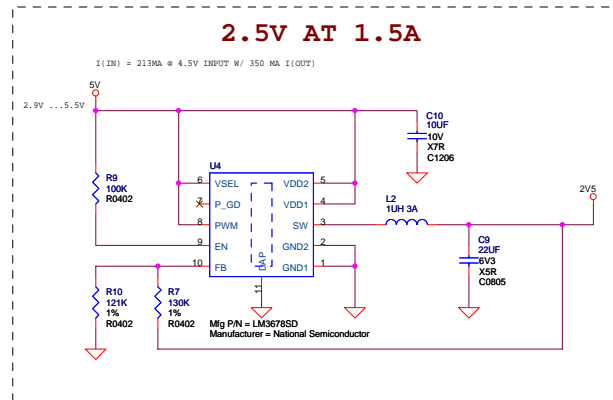

AGLP125 - CSG289

POWER & GND

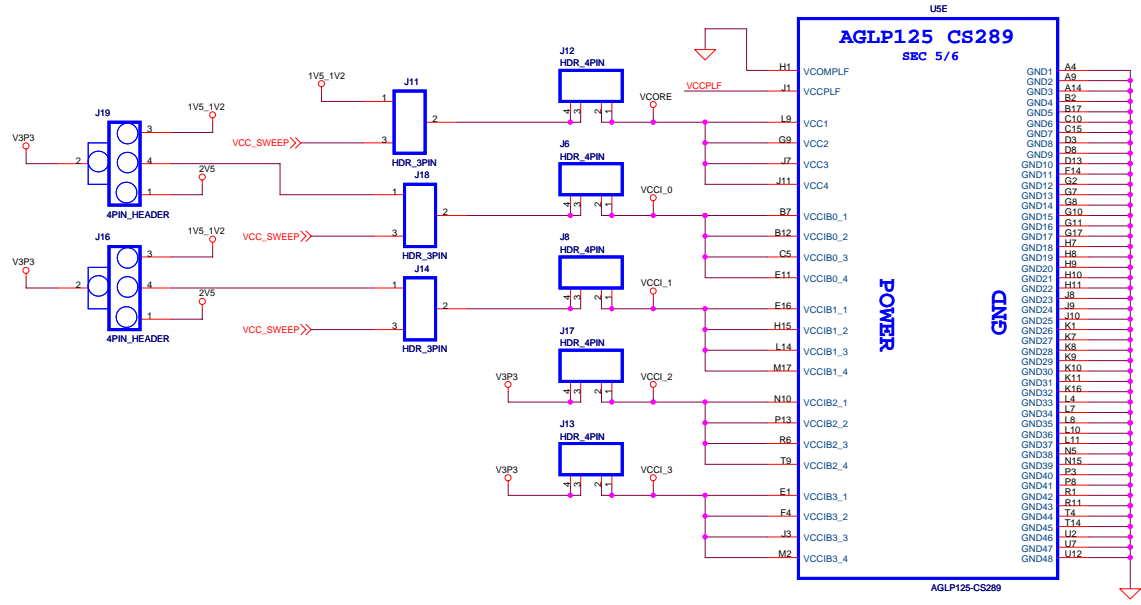

JTAG SIGNALS

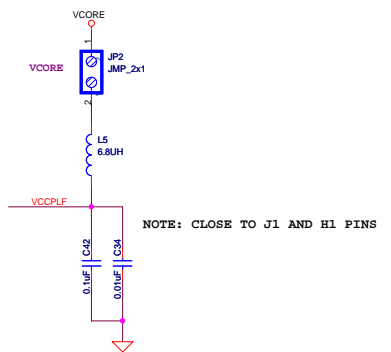
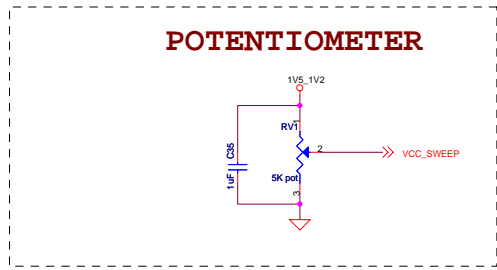
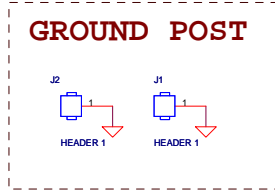
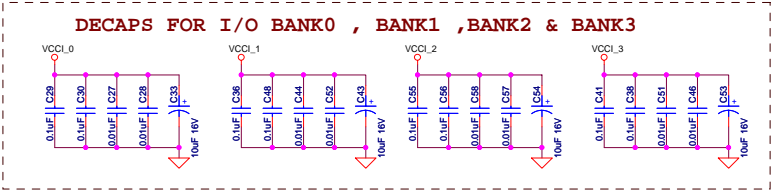
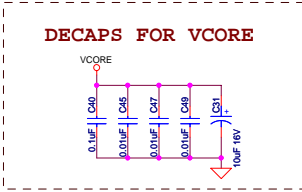
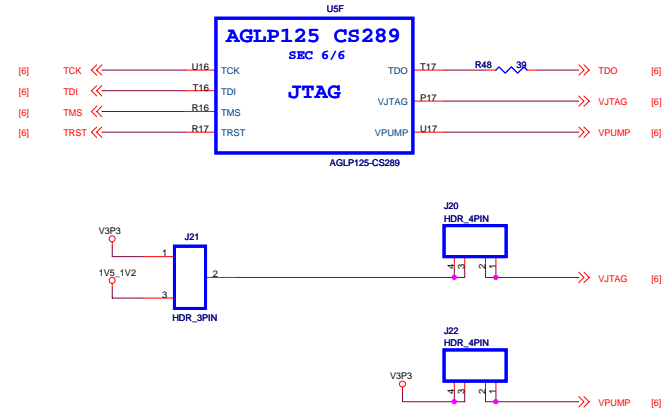

PERIPHERALS

USB TO UART

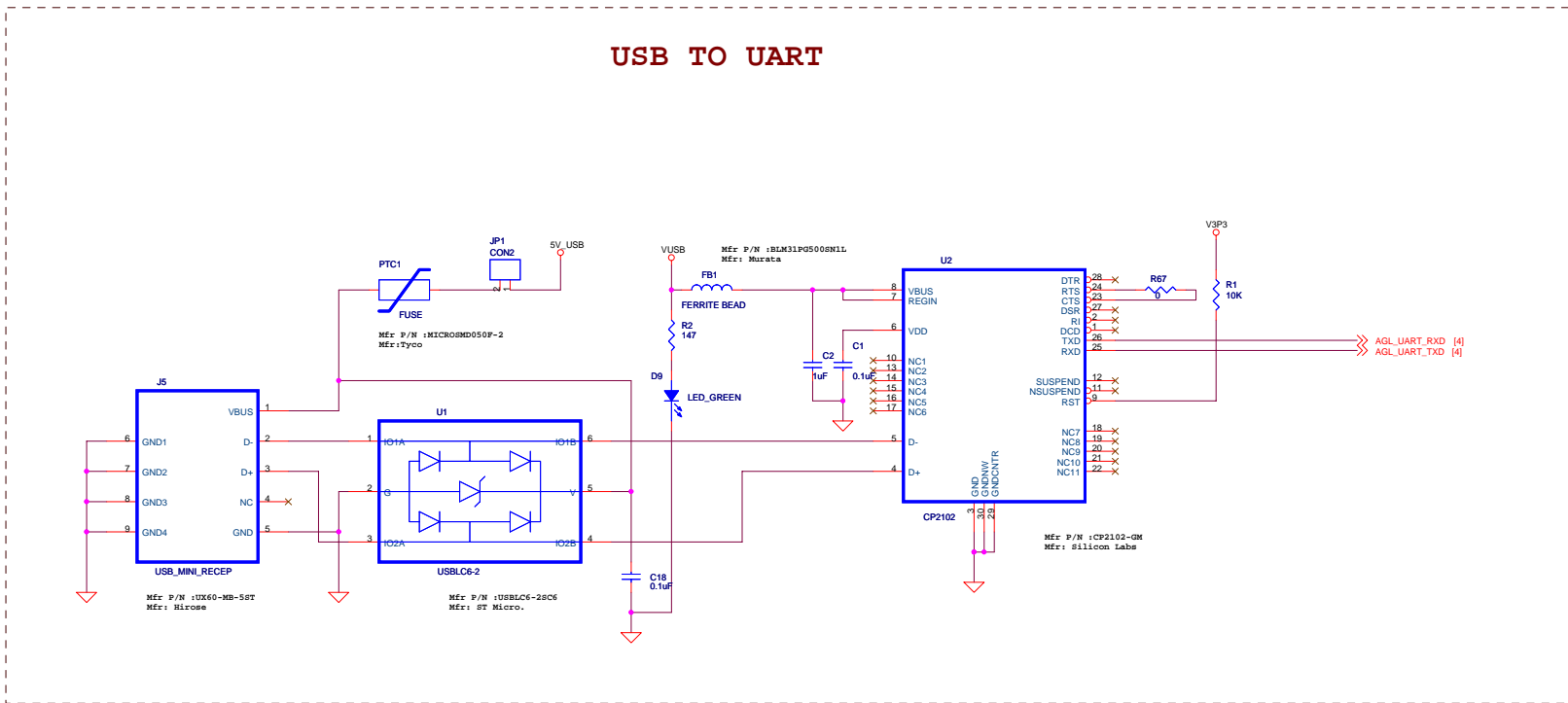

SPI FLASH

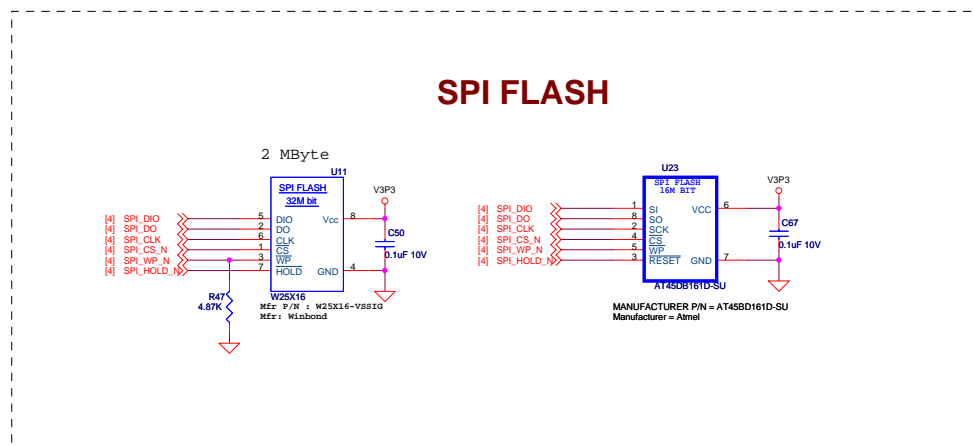

F*F VARIANTS

TWO IO CONTROLLED VIA DIP SWITCH TOGGLING HIGH OR LOW

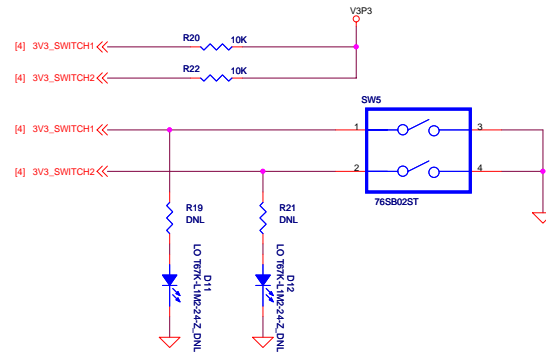

P TYPE FET

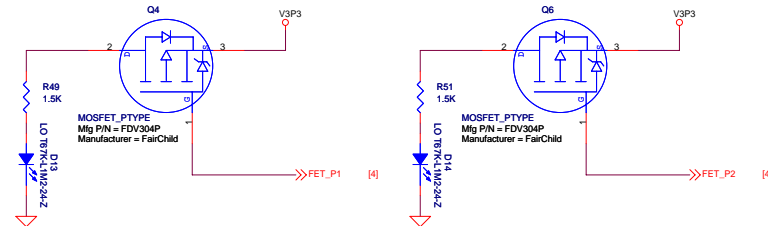

N TYPE FET

