

CCGA to CLGA Adapter Socket

Introduction

RTAX-S/SL is Actel's next generation, designed-for-space, metal-to-metal antifuse field programmable gate array (FPGA) family. RTAX-S/SL is a derivative of the Axcelerator[®] family with up to two million-system gates. RTAX-S/SL FPGAs provide the designer with nearly 500K ASIC gates and embedded static RAM. Actel offers RTAX-S/SL devices in two package styles: the Ceramic Column Grid Array (CCGA or CG) and Ceramic Quad Flat Pack (CQFP or CQ).

Actel has developed prototyping methods for RTAX-S/SL devices in CCGA and CQFP packages, using the Ceramic Land Grid Array (LGA) package as a prototyping vehicle with the CQ to LG and CG to LG adapter sockets. This document describes the procedure for assembling the CG to LG adapter socket.

CG to LG Adapter Socket

The CG to LG adapter socket has an LG configuration on the top and a CG configuration on the bottom. The adapter socket enables customers to use an LG package during prototyping, and then switch to an equivalent CG package for production. There is one CG to LG adapter socket available. The top and bottom ordering part numbers are listed in [Table 1](#).

Table 1 • Adapter Socket Part Number

Adapter Socket	Ordering Part Number	Prototyped and Prototype Device
CG1272 to LG1272	SK-RT4K-KITTOP SK-RT4K-CG1272-KITBTM	For prototyping RTAX4000S/SL-CG1272 using RTAX4000S/SL-LG1272 package

Figure 1 shows the complete CG1272 to LG1272 assembly kit. SK-RT4K-KITTOP contains an interposer (3), a socket lid (4), and eight screws (5). SK-RT4K-CG1272-KITBTM contains a ceramic adapter (1), which is a unique adapter for RTAX4000S/SL, socket housing (2), and eight screws (5).

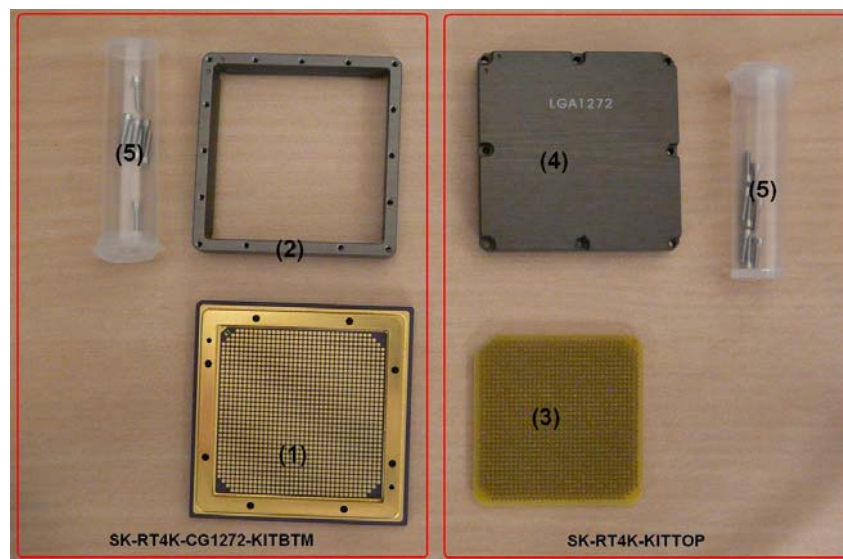

Figure 1 • Parts of CG1272 to LG1272 Adapter Socket

- (1) Ceramic Adapter, (2) Socket Housing, (3) Socket Lid, (4) Socket Interposer, (5) Fixing Screws

Figure 2 shows the top view, bottom view, and orientation view of the RTAX4000S/SL CG1272 to LG1272 adapter.

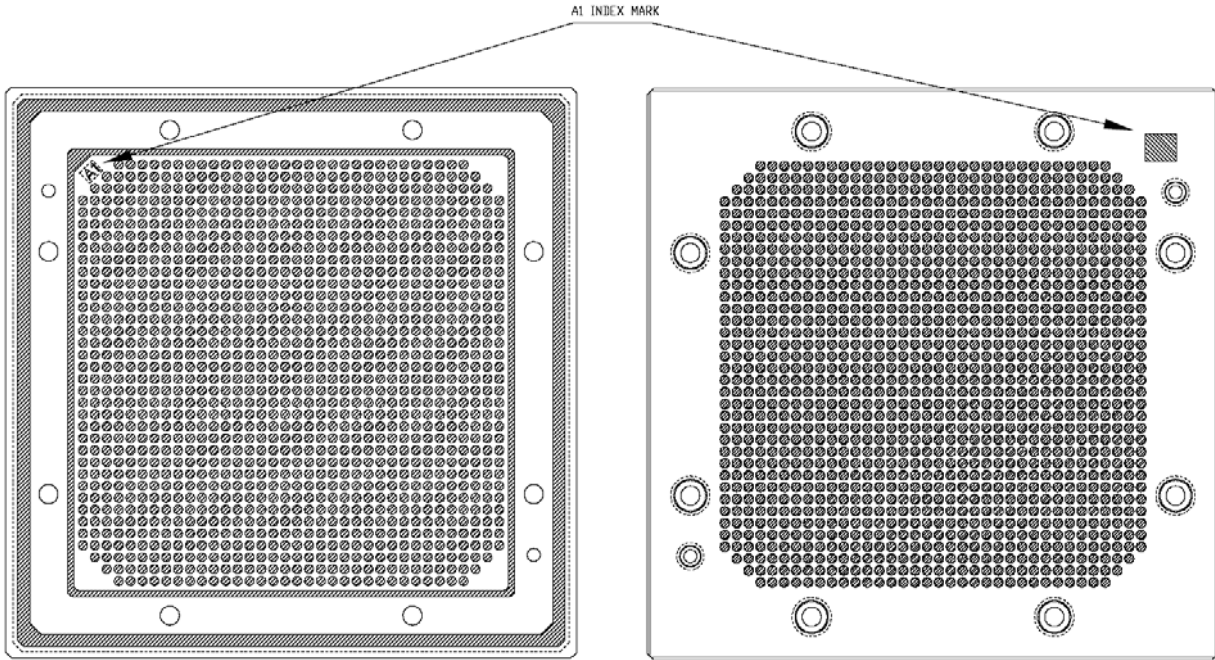

Figure 2 • RTAX4000S/SL CG1272 to LG1272 Ceramic Adapter
Top View, Bottom View and Orientation Drawing

CG to LG Adapter Socket Assembly Procedure

Step 1

Solder column attachment to ceramic adapter.

Note: Do NOT reflow the adapter to the circuit board until the housing has been attached, as detailed in Step 2 below.

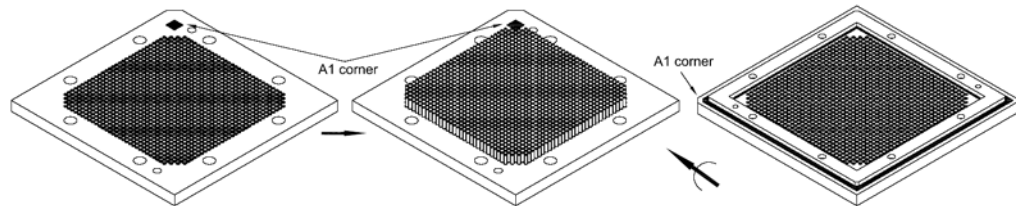

Figure 3 • CG1272 to LG1272 Adapter Solder Column Attachment

Step 2

Assemble socket housing to adapter. A torque limit screw driver is not required (Figure 4).

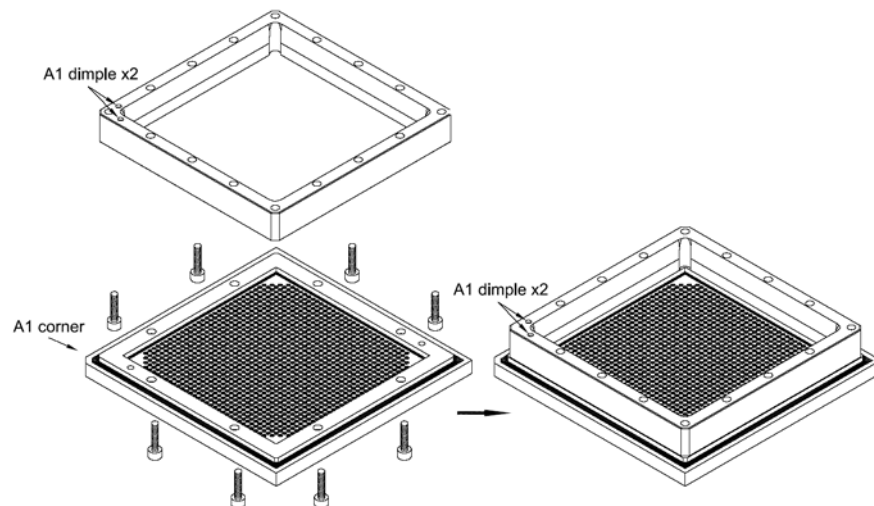

Figure 4 • Assemble Socket Housing to CG1272 to LG1272 Adapter

Note: The housing, eight screws, and ceramic adapter form the –KITBTM assembly.

Step 3

Reflow the adapter to the printed circuit board (PCB) as shown in (Figure 5).

Note: Since reflow profiles depend upon the size of the board and its components, perform reflow process optimization for better results.

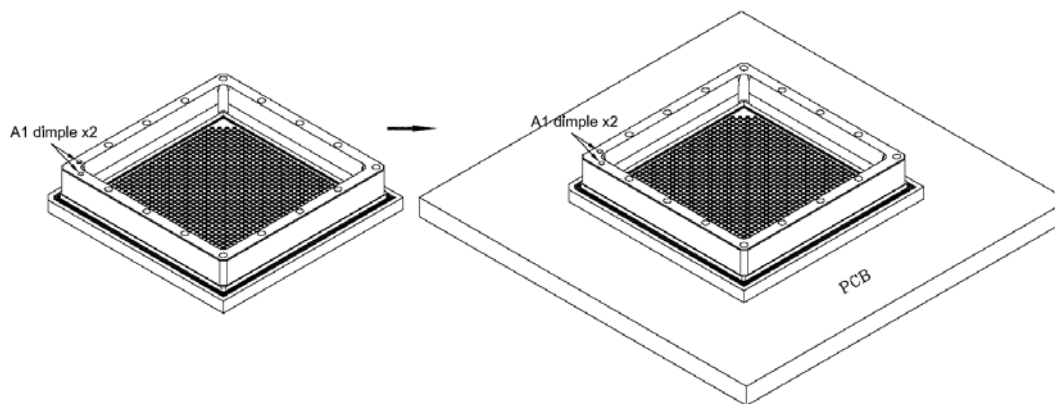

Figure 5 • Reflow Adapter (with socket housing mounted) to PCB

Step 4

Place the socket interposer into the adapter (Figure 6).

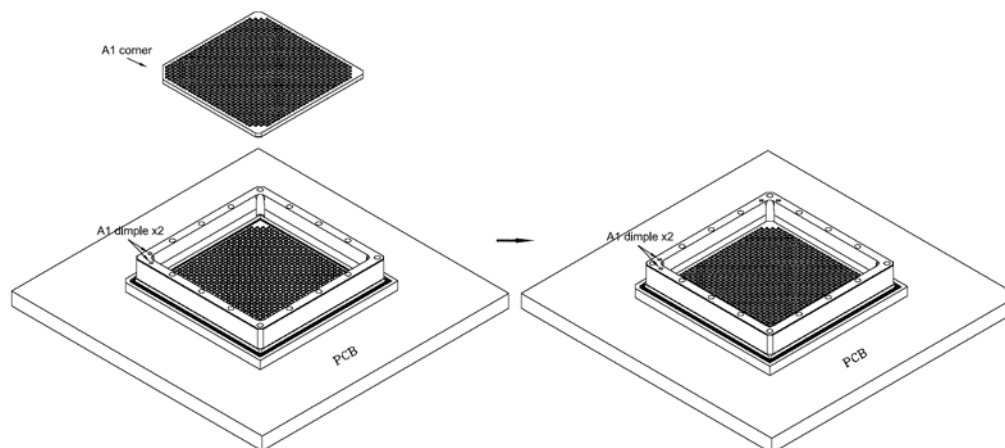

Figure 6 • Place the Socket Interposer into Adapter Assembly

Step 5

Place the LG1272 package into the adapter (Figure 7).

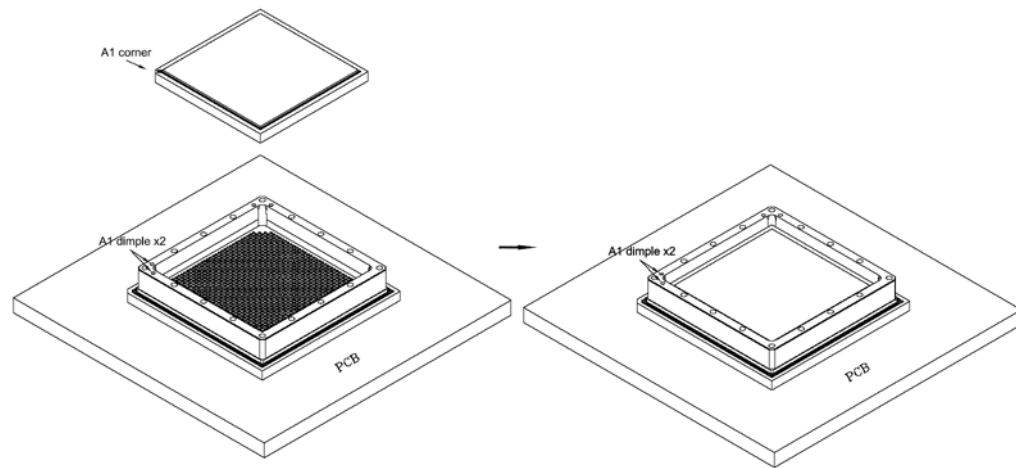

Figure 7 • Place LG1272 Package into Adapter Assembly

Step 6

Place and tighten the socket lid to the socket housing with the remaining eight screws (Figure 8). A torque limit screw driver is not required.

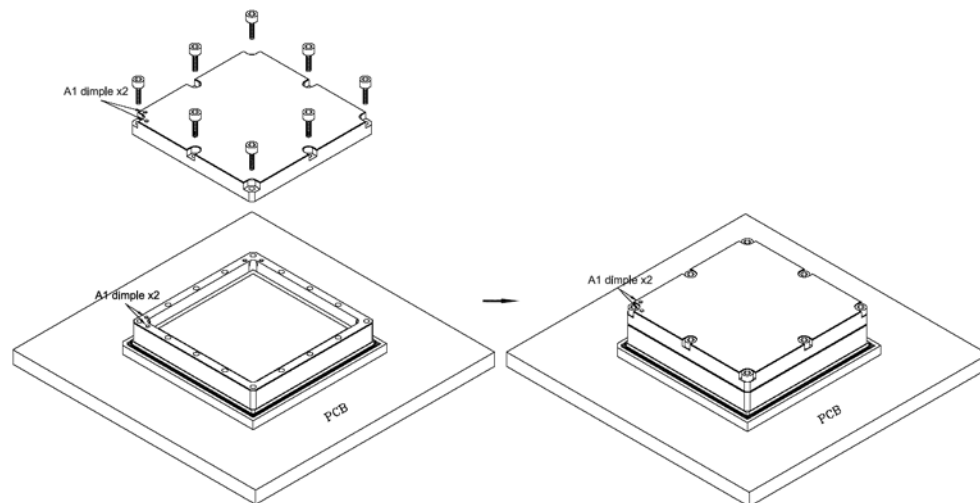

Figure 8 • Place and Tighten Socket Lid Using Eight Screws and Optional Alignment Pins

CG1272 to LG1272 Adapter Socket Outline Drawing

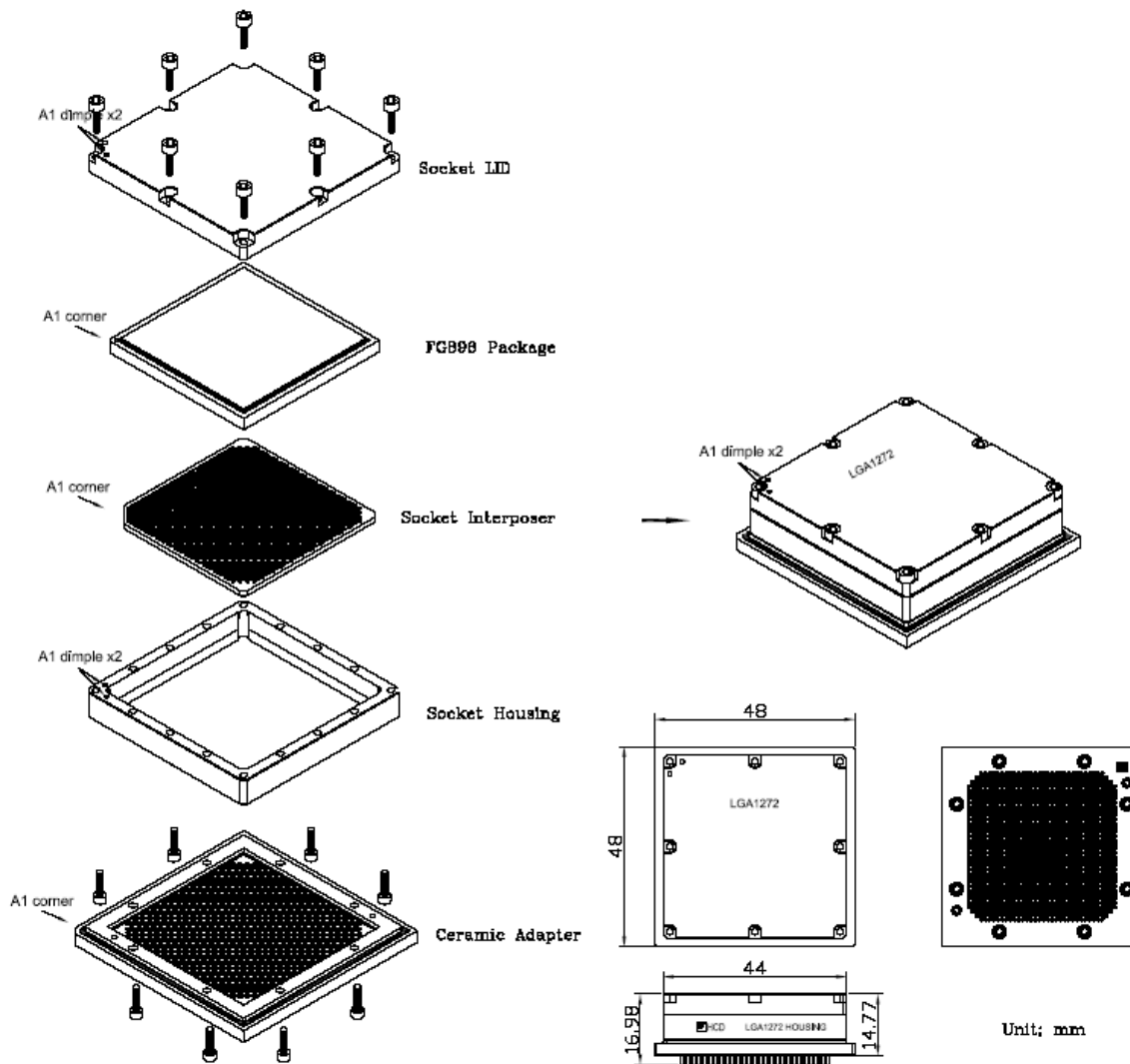

Figure 9 • CG1272 to LG1272 Adapter Socket Outline Drawing (unit: mm)

Reflow Profile

Since reflow profile depends upon the size of the board and other components, end users should perform additional fine tuning from the general profile, as shown in [Figure 10](#).

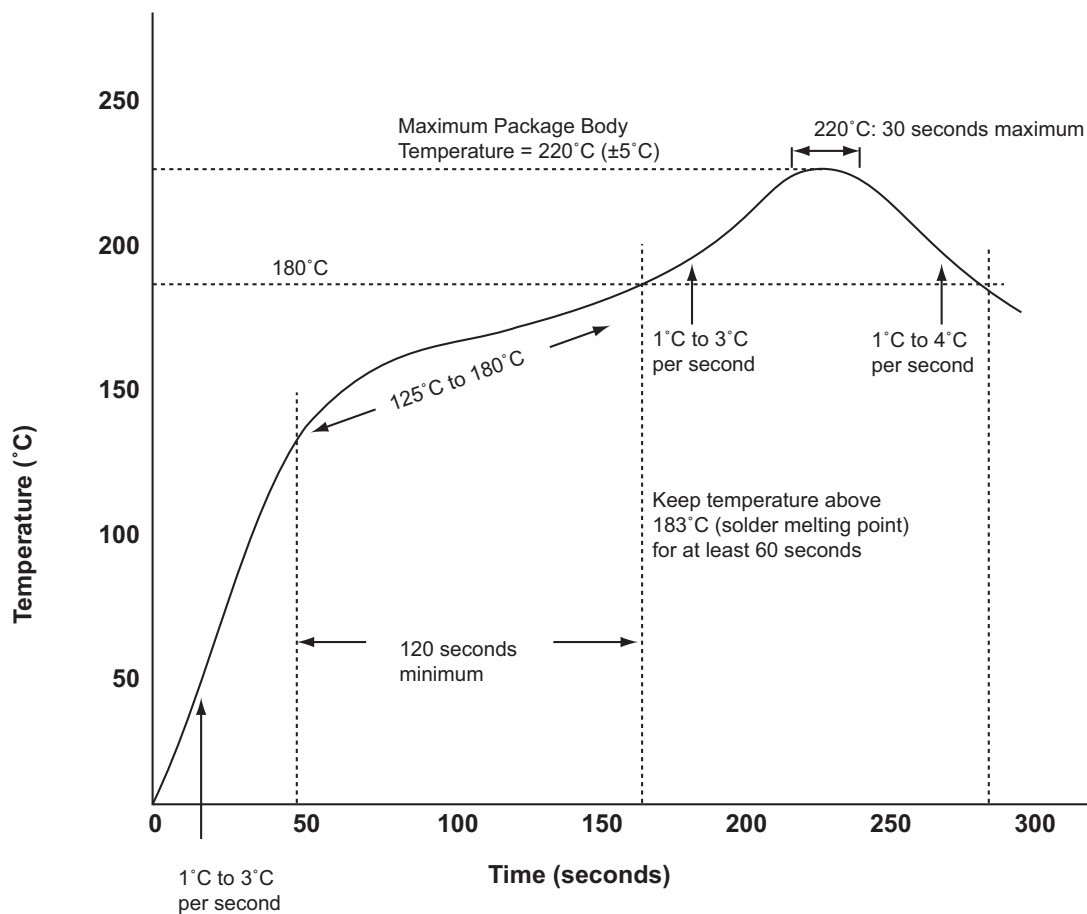

Figure 10 • Sample Temperature Profile for I/R or Convection Reflow

Note: This temperature profile guideline is for reference only.

CCGA to LG1272 Adapter Pin Mapping List

The CG1272 to LG1272 adapter is same number pad connection routing. For example, LG1272 A1 connects to CG1272 A1, LG1272 A2 connects to CG1272 A2, and so on.

Table 2 • CCGA to LG1272 Adapter Pin Mapping List

Adapter Socket	Ordering Part Number	Prototyped and Prototype Device	Adapter Pin Mapping List Document Number
CG1272 to LG1272	SK-RT4K-KITTOP and SK-RT4K-CG1272-KITBTM	For prototyping RTAX4000S/SL-CG1272 using RTAX4000S/SL-LG1272 package	N/A

Prototyped Product, Adapter, and PCB Design Matrix

Designing the PCB for a specific product requires an understanding of which adapter socket will work. Each adapter socket is routed differently based on the corresponding Axcelerator device (or its radiation-tolerant equivalent derivative that is being prototyped) and the commercial Axcelerator FG package used for prototyping. Table 3 shows the combinations that will work.

Table 3 • Prototyped Product, Adapter, and PCB Design Matrix

Prototyped Product	Adapter Part Number	Prototype Vehicle	PCB Design
RTAX4000S/SL-CG1272	SK-RT4K-KITTOP and SK-RT4K-CG1272-KITBTM	RTAX4000S/SL-LG1272	RTAX4000S/SL-CG1272

Support

Visit Technical Support online at www.actel.com/kb/search.aspx.

Email Technical Support at tech@actel.com

Call Technical Support 7:00 A.M. to 6:00 P.M Pacific Time, Monday through Friday: (800) 262-1060 or 650-318-4460.

List of Changes

The following table lists critical changes that were made in the current version of the document.

Revision	Changes	Page
Revision 1 (August 2010)	In the "Introduction" section, the phrase "with error detection and correction (EDAC) protected" [static RAM] was deleted and replaced with "embedded."	1
	The following figures were replaced (27425): Figure 1 • Parts of CG1272 to LG1272 Adapter Socket Figure 2 • RTAX4000S/SL CG1272 to LG1272 Ceramic Adapter Figure 5 • Reflow Adapter (with socket housing mounted) to PCB Figure 9 • CG1272 to LG1272 Adapter Socket Outline Drawing (unit: mm)	1 2 4 6



Actel is the leader in low power FPGAs and mixed signal FPGAs and offers the most comprehensive portfolio of system and power management solutions. Power Matters. Learn more at www.actel.com.

Actel Corporation

2061 Stierlin Court
Mountain View, CA
94043-4655 USA
Phone 650.318.4200
Fax 650.318.4600

Actel Europe Ltd.

River Court, Meadows Business Park
Station Approach, Blackwater
Camberley Surrey GU17 9AB
United Kingdom
Phone +44 (0) 1276 609 300
Fax +44 (0) 1276 607 540

Actel Japan

EXOS Ebisu Building 4F
1-24-14 Ebisu Shibuya-ku
Tokyo 150 Japan
Phone +81.03.3445.7671
Fax +81.03.3445.7668
<http://jp.actel.com>

Actel Hong Kong

Room 2107, China Resources Building
26 Harbour Road
Wanchai, Hong Kong
Phone +852 2185 6460
Fax +852 2185 6488
www.actel.com.cn