

Performing Microprocessor Programming for Actel ProASIC^{PLUS} Devices

Introduction

The ProASIC^{PLUS} family of devices, Actel's second generation Flash FPGA, offers enhanced performance over Actel's ProASIC family of devices. ProASIC^{PLUS} devices combine the advantages of ASICs with the benefits of programmable devices through nonvolatile Flash technology. This combination enables engineers to create high-density systems using an existing ASIC or FPGA design flow and tools.

This application note describes the requirements to program the ProASIC^{PLUS} device through a microprocessor or microcontroller using STAPL player or Actel's DirectC.

Overview

You can program the FPGA using a microprocessor that is already in the system during the manufacturing process or during field upgrades. There are three main programming elements when using a microprocessor: hardware, a software program that executes the programming instructions, and programming data.

Hardware Requirements

To facilitate programming of a ProASIC^{PLUS} device, the system must have a microprocessor to process the programming algorithms, a clock source to generate TCK or RCK, memory to store the programming algorithms, programming data (see [Table 1](#) for recommended RAM size for STAPL files), and the necessary programming voltages (see [Table 2 on page 2](#) for voltage requirements). ProASIC^{PLUS} devices are programmed through the JTAG port; therefore, the microprocessor must have access to the JTAG pins of the ProASIC^{PLUS} device ([Figure 1 on page 2](#)).

Table 1 • Recommended RAM Size for STAPL Files

Device	Recommended RAM Size
APA075	100 kB
APA150	200 kB
APA300	250 kB
APA450	350 kB
APA600	700 kB
APA750	1 MB
APA1000	1 MB

Table 2 • Voltage Requirements

Power Supply	Normal Operation	Programming Mode	Current During Programming
V _{DD}	2.5V	2.3V to 2.7V	IVDD < 20 mA at V _{DD}
V _{DDP}	2.5V or 3.3V ¹	2.3V to 2.7V or 3.0V to 3.6V	IVDDP < 20 mA at V _{DDP}
V _{PP}	0V to 16.5V or floating ²	15.8 to 16.5V	IVPP < 35 mA at V _{PP}
V _{PN}	-13.8V to 0V or floating ³	-13.8V to -13.2V	IVPN < 15 mA at V _{PN}

Notes:

1. Stresses beyond the maximum voltages listed in the table may cause permanent damage to the device. Devices should not be operated outside of the Recommended Operating Conditions. See the *ProASIC^{PLUS} Flash Family FPGAs* datasheet.
2. There is a nominal 40kΩ pull-up resistor on V_{PP}.
3. There is a nominal 40kΩ pull-down resistor on V_{PN}.
4. Absolute maximum rating on V_{PN} is 0.5V. Stresses beyond this limit may damage the device.

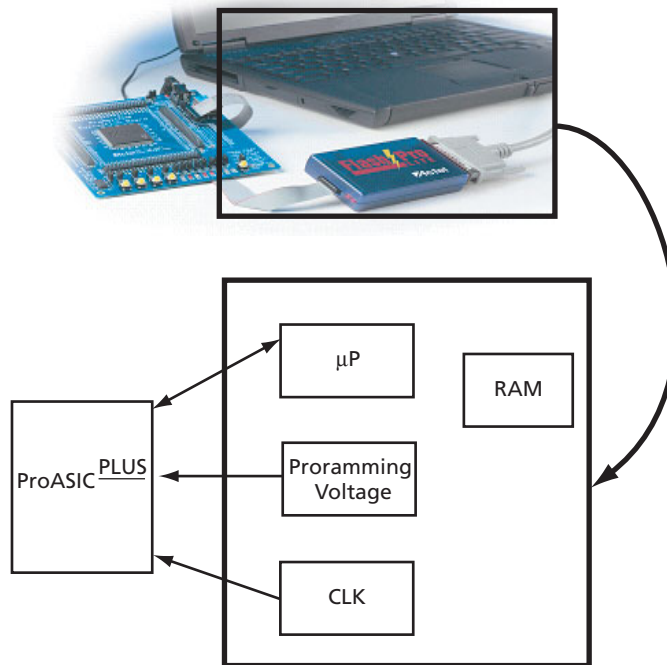

Figure 1 • Relationship Between FlashPro and an Internal System

DirectC vs. STAPL Software Requirements

ProASIC^{PLUS} devices can be programmed using DirectC or a STAPL player. Both tools use the STAPL file as an input. DirectC is a compiled language, whereas the STAPL player is an interpreted language. Being a compiled language, DirectC is much faster to execute than the STAPL player. This speed advantage becomes more apparent when the microprocessor becomes smaller and slower.

DirectC also requires less memory than the STAPL player. However, the STAPL player does have one advantage over DirectC, the ability to upgrade. When a new programming algorithm is required, the STAPL player user only has to regenerate a STAPL file using the latest version of Designer software and download it into the system. The DirectC user must download the latest version of DirectC from Actel, recompile the design, and then download into the system. See [Figure 2](#) for a flow comparison of DirectC and STAPL player.

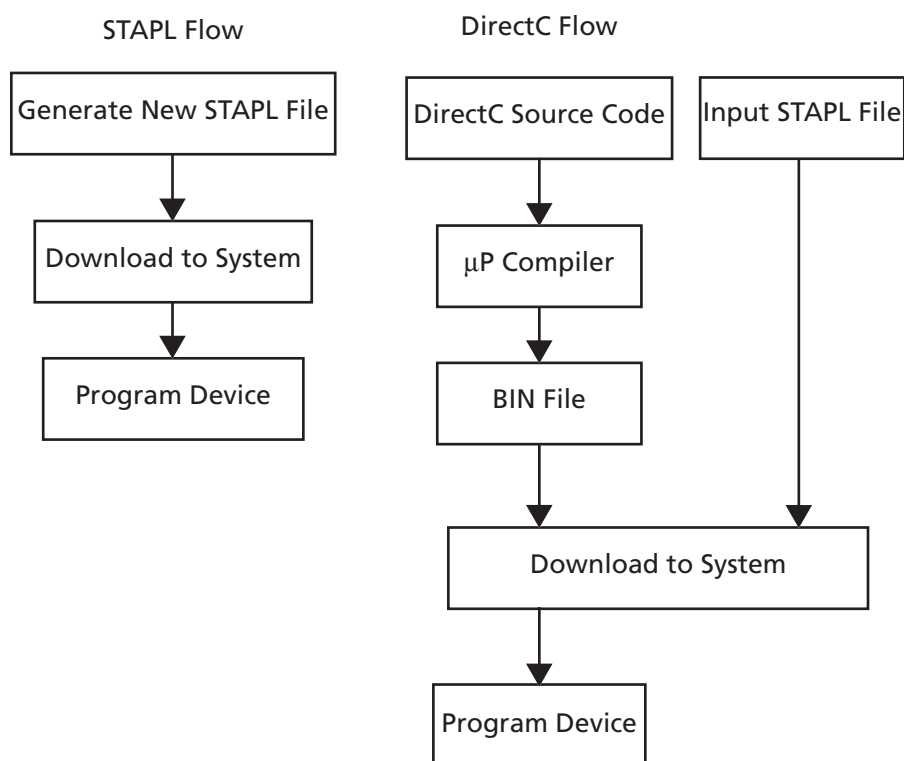

Figure 2 • DirectC and STAPL Player Flow Comparison

Deployment

Both DirectC and the STAPL player can be downloaded from Actel's website. The DirectC and the STAPL player code from Actel's website are generic; they need to be modified according to the system configuration. There are two types of modifications, system-level modifications and Hardware Abstraction Layer Application Protocol Interface (HAL API) modifications.

System-level modifications are required on functions related to the system. These functions control memory allocation within the system, timing functions, clock source, and clock frequencies.

Hardware Abstraction Layer Application Protocol Interface modifications are required on functions that relate to inputs/outputs. The DirectC and STAPL player code will make the JTAG level call to the HAL's API, then it is up to the HAL's API to map the JTAG calls to the low-level I/O functions.

Once the necessary modifications are completed, the code will be compiled and downloaded into the system. See [Figure 3](#) on page 4 for deployment flow.

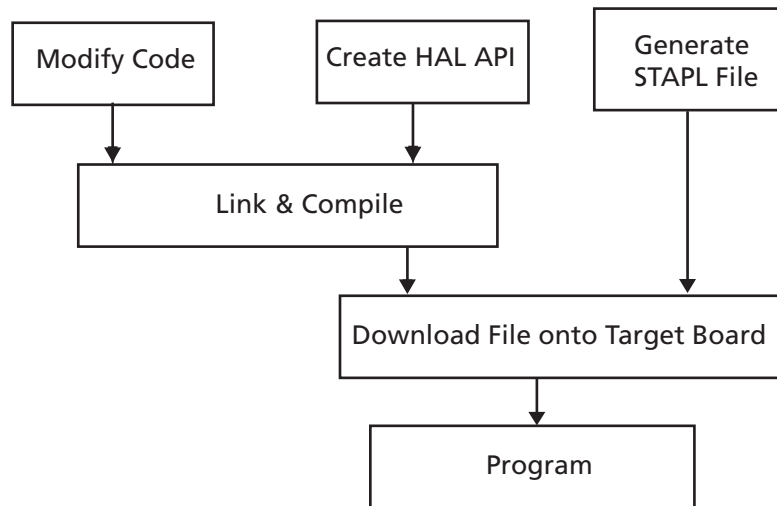

Figure 3 • Deployment Flow

TCK vs. RCK

The ProASIC^{PLUS} device is programmed using the JTAG port; therefore, TCK is used during normal communication between the microprocessor and the device. The Flash cells within the ProASIC^{PLUS} devices require a programming pulse of a certain length. This programming pulse is self-timed by the FPGA using a continuous and noninterruptible clock source. This clock can be fed into the device through TCK or RCK. If RCK is selected, the RCK clock input is only used during the programming and can be left connected during normal operations. Use RCK unless the target system can guarantee a continuous fixed frequency, TCK, which is present during waits. For most applications, RCK should be used for the programming clock to simplify the implementation of TCK.

Conclusion

ProASIC^{PLUS} devices can be programmed with a microprocessor using either DirectC or STAPL player. You can use either DirectC or a STAPL player depending on your system. If your system has a slow microprocessor and programming time is important to you, then use DirectC. If programming time is not a concern for you, then use STAPL player because it's easy to maintain.

Related Documents

Datasheets

ProASIC^{PLUS} Flash Family FPGAs

http://www.actel.com/documents/ProASICPlus_DS.pdf

Appendix A: Suggested Voltage Generator Circuit

A circuit for generating the required voltages for internal ISP is shown in Figure 3 and Figure 4. See Table 3 and Table 4 on page 6 for a list of Building Materials required for building circuits. There are two Linear Tech voltage converters in the circuit. Application notes for each of them can be found at:

Positive Converter

www.linear-tech.com/pdf/1930f.pdf

Linear Converter

www.linear-tech.com/pdf/1931f.pdf

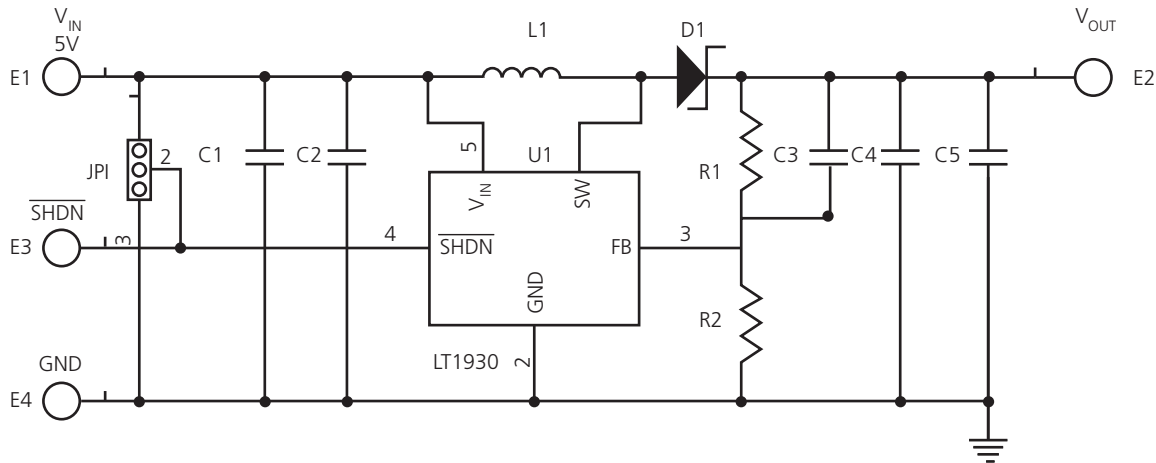

Figure 4 • Boost Schematic

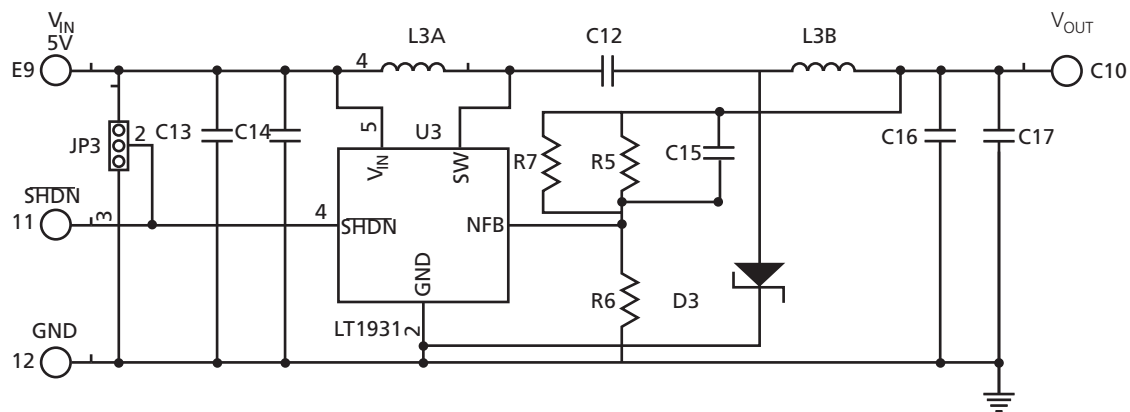

Figure 5 • Inverter Schematic

Table 3 • Boost Circuit

Item	Quantity	Reference	Part Description
1	2	C1, C5	CAP, X5R, 1 μ F, 16V, 0805
2	1	C2	CAP, X5R, 2.2 μ F, 16V, 1206
3	1	C3	CAP, NPO, 10pF, 25V, 10%, 0402
4	1	C4	CAP, X5R, 4.7 μ F, 16V, 1206
5	1	D1	DIO, SCHOTTKY, 30V, 0.5A
6	1	L1	Inductor, 10 μ H, 20%
7	1	R1	RES, CHIP, 156K, 1/16W, 1%, 0402
8	1	R2	RES, CHIP, 13.3K, 1/16W, 1%, 0402
9	1	U1	I.C., LINEAR, LT1930ES5#25117

Table 4 • Inverter Circuit

Item	Quantity	Reference	Part Description
1	2	C13, C17	CAP, X5R, 1 μ F, 16V, 0805
2	2	C14, C16	CAP, X5R, 4.7 μ F, 16V, 1206
3	1	C12	CAP, X5R, 1 μ F, 25V, 1206
4	1	D3	DIO, SCHOTTKY, 30V, 0.5A
5	2	L3A, L3B	Inductor, 10 μ H, 30%
6	1	R5	RES, CHIP, 10K, 1/16W, 0.1%, 0402
7	1	R6	RES, CHIP, 1K, 1/16W, 0.1%, 0402
8	1	R7	RES, CHIP, 402K, 1/16W, 1%, 0402
9	1	U3	I.C., LINEAR, LT1931ES5#25118

Actel and the Actel logo are registered trademarks of Actel Corporation.
All other trademarks are the property of their owners.



<http://www.actel.com>

Actel Corporation

2061 Stierlin Court
Mountain View, CA
94043-4655 USA

Phone 650.318.4200
Fax 650.318.4600

Actel Europe Ltd.

Dunlop House, Riverside Way
Camberley, Surrey GU15 3YL
United Kingdom

Phone +44 (0) 1276 401 450
Fax +44 (0) 1276 401 490

Actel Japan

EXOS Ebisu Bldg. 4F
1-24-14 Ebisu Shibuya-ku
Tokyo 150 Japan

Phone +81.03.3445.7671
Fax +81.03.3445.7668

Actel Hong Kong

39th Floor, One Pacific Place
88 Queensway, Admiralty
Hong Kong

Phone 852.227.35712
Fax 852.227.35999