

In-System Programming ProASIC^{PLUS} Devices

Introduction

To decrease time-to-market, designers often use in-system programming (ISP) field programmable gate arrays (FPGAs). Compared to traditional FPGAs, Actel's flash-based ProASIC^{PLUS} devices do not require an external boot PROM to support device programming. While on-board security mechanisms prevent all access to the program information, reprogramming can be performed in-system to support future design iterations and field upgrades. This application note describes the requirements for programming a ProASIC^{PLUS} device and specific requirements when using Silicon Sculptor, FlashPro, and FlashPro Lite.

If you are not sure which method of in-system programming to use, refer to the "Programming Flash Devices" chapter of the *ProASIC3 FPGA Fabric User's Guide*, which explains the differences between the various programming solutions Actel offers.

ISP Setup

To facilitate the ISP of ProASIC^{PLUS} devices, Actel provides three solutions: FlashPro, FlashPro Lite, and Silicon Sculptor 3 (or Silicon Sculptor II) with an add-on ISP Kit.

Figure 1 shows the programming setup with FlashPro and Silicon Sculptor.



Figure 1 • Programming Setup

ProASIC^{PLUS} Device Programming Requirements

During programming, all I/O pins, except for JTAG interface pins, are tristated and pulled up to V_{DDP} . This isolates the part and prevents the signals from floating.

Interruptions in the programming sequence may result in unpredictable behavior of a partially programmed device. Additionally, switches that are programmed incorrectly can cause high current flow through the circuitry, resulting in permanent damage to the device.

Power Supply Configurations

Two power supplies, one for the V_{DD} pins and the other for the V_{DDP} pins, are needed in normal operation. V_{DD} powers the core and V_{DDP} powers the I/O pads. V_{DD} must be set to 2.5 V (± 0.2 V), and V_{DDP} can be set to either 2.5 V (± 0.2 V) or 3.3 V (± 0.3 V) (Table 1).

During Programming for ProASIC^{PLUS} devices, V_{DDP} supplies power to the JTAG I/Os and V_{DD} supplies power to the programming circuit. In addition to the low voltage power supplies (V_{DD} and V_{DDP}), two high voltage sources (V_{PP} and V_{PN}) are necessary (Table 1).

FlashPro

If FlashPro is used for programming, all programming voltages (V_{DD} , V_{DDP} , V_{PP} and V_{PN}) can be provided by FlashPro. However, the V_{DD} and V_{DDP} supplies of ProASIC^{PLUS} devices can be provided from the target, while the V_{PP} and V_{PN} are still supplied by FlashPro. Corresponding FlashPro software configuration is needed to uncheck the V_{DD} and V_{DDP} supply from FlashPro.

FlashPro Lite

If FlashPro Lite is used for programming, the programmer derives all of its power from the target board's V_{DD} supply. The FlashPro Lite's V_{PP} and V_{PN} power supplies use the target board's V_{DD} as a power source. The target board must supply power to both the V_{DDP} and V_{DD} power pins of the ProASIC^{PLUS} device in addition to supplying V_{DD} to the FlashPro Lite. The target board needs to provide at least 500mA of current to the FlashPro Lite V_{DD} connection for programming.

Silicon Sculptor 3 and Silicon Sculptor II

If Silicon Sculptor 3 / Silicon Sculptor II is used for programming, the programmer is providing all the power supplies. However, you can also choose to power up the V_{DD} and V_{DDP} supplies of the ProASIC^{PLUS} devices from the target, if you disconnect the V_{DD} and V_{DDP} supplies from the Silicon Sculptor 3 / Silicon Sculptor II.

The typical current consumption for each programming pin during programming is shown in Table 1.

Table 1 • ProASIC^{PLUS} Voltages and Currents

Power Supply	Normal Operation	Programming Mode	Current During Programming
V_{DD}	2.5 V	2.3 V to 2.7 V	$I_{VDD} < 20$ mA at V_{DD}
V_{DDP}	2.5 V or 3.3 V ¹	2.3 V to 2.7 V or 3.0 V to 3.6 V	$I_{VDDP} < 20$ mA at V_{DDP}
V_{PP}	0 V to 16.5 V or floating ²	15.8 V to 16.5 V	$I_{VPP} < 35$ mA at V_{PP}
V_{PN}	-13.8 V to 0 V or floating ³	-13.8 V to -13.2 V	$I_{VPN} < 15$ mA at V_{PN}

Notes:

1. Stresses beyond the maximum voltages listed in the table may cause permanent damage to the device. Devices should not be operated outside of the Recommended Operating Conditions. See the ProASIC^{PLUS} Flash Family FPGAs datasheet.
2. There is a nominal 40 k Ω pull-up resistor on V_{PP} .
3. There is a nominal 40 k Ω pull-down resistor on V_{PN} .
4. Absolute maximum rating on V_{PN} is 0.5 V. Stresses beyond this limit may damage the device.

Board Considerations

ProASIC^{PLUS} Devices – APA450, APA600, APA750, APA1000

Actel requires bypass capacitors from V_{PP} to GND and V_{PN} to GND for APA450, APA600, APA750, and APA1000 devices during programming. During the erase cycle, ProASIC^{PLUS} devices may have current surges on the V_{PP} and V_{PN} power supplies. The only way to maintain the integrity of the power distribution to the ProASIC^{PLUS} device during these current surges is to counteract the inductance of the finite length conductors that distribute the power to the device. This can be accomplished by providing sufficient bypass capacitance between the V_{PP} and V_{PN} pins and GND (using the shortest paths possible). Without sufficient bypass capacitance to counteract the inductance, the V_{PP} and V_{PN} pins may incur a voltage spike beyond the voltage that the device can withstand.

Use a 0.01 μF to 0.1 μF ceramic capacitor with a 25 V or greater rating. To filter low-frequency noise (decoupling), use a 4.7 μF (low ESR, $<1 \Omega$, tantalum, 25 V or greater rating) capacitor. The capacitors should be located as close to the device pins as possible (within 2.5 cm is desirable). The smaller, high-frequency capacitor should be placed closer to the device pins than the larger low-frequency capacitor. The same dual capacitor circuit should be used on both the V_{PP} and V_{PN} pins (Figure 2).

Pay close attention to the polarity of the tantalum caps when laying out the board. The positive should connect to ground for V_{PN} .

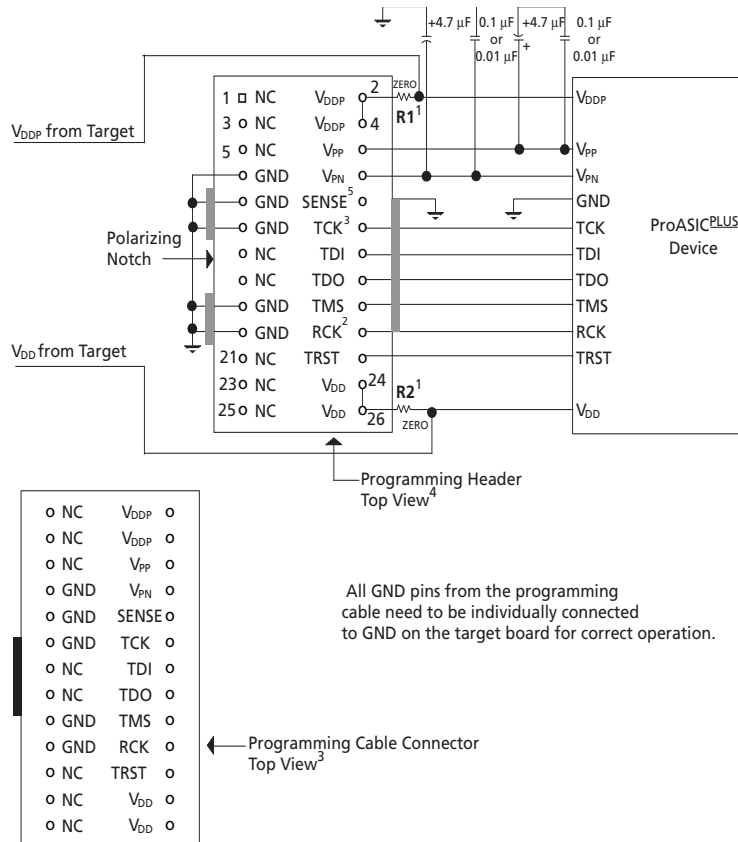

Notes:

1. For information on the 0Ω resistor, refer to the "Programmer Specific Requirements" section on page 4 for details.
2. For FlashPro and FlashPro Lite, use TCK, and for Silicon Sculptor use both RCK and TCK.
3. This is the output of the programmer. This diagram shows the signals that the programmer will drive onto the header in programming mode.
4. This is the pinout of the programming header on the printed circuit board (PCB). The signals that appear on the header must be connected to the ProASIC^{PLUS} device.
5. The SENSE pin is connected to the GND on the target board and is used to indicate to the FlashPro or FlashPro Lite programmer that the cable is correctly connected to the target board.

Figure 2 • ProASIC^{PLUS} ISP Board Layout and Programming Connector Top View

ProASIC^{PLUS} Devices – APA075, APA150, APA300

These devices do not require bypass capacitors on the V_{PP} and V_{PN} pins as long as the total combined distance of the programming cable and the trace length on the board for each pin is less than or equal to 18 inches.

For trace lengths greater than 18 inches, use the bypass capacitor recommendations in the previous section.

Programmer Specific Requirements

FlashPro

- Programming Clock signal—Only TCK is used.
- Programming file—Only STAPL files are supported.
- Daisy Chain—Supported.
- To bypass non-Actel devices, the user will need to create chain specific STAPL files using ChainBuilder. For more information on ChainBuilder, please refer to the [ChainBuilder User's Guide](#).
- Power Supply
 - Solution 1: The 0 Ω resistor links, R1 and R2 in [Figure 2 on page 3](#), should be populated if the programmer is providing the V_{DD} and V_{DDP} supplies. Or they can be replaced by wires on the PCB to meet easy layout and low cost requirements. Make sure the V_{DD} and V_{DDP} supplies from the target can handle the power supply from the programmer, otherwise use solution 2.
 - Solution 2: The 0 Ω resistors, R1 and R2 in [Figure 2 on page 3](#), are optional if the target is providing the V_{DD} and V_{DDP} supplies. Uncheck the V_{DD} and V_{DDP} supplies from FlashPro in the software.

FlashPro Lite

- Programming clock signal—Only TCK is used.
- Programming file—Only STAPL files are supported.
- Daisy Chain—Supported. FlashPro Lite will get the bypass devices information from the “device.db” file. You can manually edit the “device.db” file to add in more devices that are not in the original device list. For more details, contact Actel Tech Support.
- Power Supply

FlashPro Lite derives power from target V_{DD} supply. The 0 Ω resistor, R2 in [Figure 2 on page 3](#), should always be populated or it can be replaced by the wire on the printed circuit board (PCB) to meet easy layout and low-cost concern. The 0 Ω resistor, R1 in [Figure 2 on page 3](#), is optional at any time or you can cut off the trace from the target V_{DDP} supply to the programming header V_{DDP} pin.

Silicon Sculptor 3 / Silicon Sculptor II

- Programming clock signal—Both RCK and TCK are used.
- Programming file—Both BIT and STAPL files are supported.
- Daisy Chain—Only supports chains of ProASIC or ProASIC^{PLUS} devices. Refer to ProASIC Daisy-Chain Programming for similar applications.
- Power Supply
 - Solution 1: The 0 Ω resistor links, R1 and R2 in [Figure 2 on page 3](#), should be populated if the programmer is providing the V_{DD} and V_{DDP} supplies, or they can be replaced by wires on the PCB to meet easy layout and low cost requirements. Make sure the V_{DD} and V_{DDP} supplies from the target can handle the power supply from the programmer, otherwise use solution 2.
 - Solution 2: The 0 Ω resistor links, R1 and R2 in [Figure 2 on page 3](#), should not be populated if the target is providing the V_{DD} and V_{DDP} supplies.

Signal Integrity

This section describes signal integrity in relation to the ISP of Actel ProASIC^{PLUS} devices and answers some common questions.

Importance of Signal Integrity

Without reasonably clean signals on the JTAG nets, reliable communication with the parts is not possible. The result of bad signal quality is programming failures with good parts, or in extreme cases, an inability to communicate with the part at all. It is even possible to cause physical damage to the ProASIC^{PLUS} device due to an electrical overstress of the tunnel oxide during programming and erasing of the part.

The JTAG specification defines a state machine, the Test Access Port (TAP) controller, which controls communication over the JTAG bus. There are two TAP controllers when talking to a JTAG slave, the JTAG controller and the JTAG slave. These two controllers must dance in lock-step for communication to take place. If the slave gets out of step, communication to the slave is lost until the two controllers are synchronized again. In the case of device programming, the JTAG controller resides in the programmer and the programming software. The JTAG slave is a hardware state machine in the ProASIC^{PLUS} device. Transitions between the different TAP states are controlled by the JTAG TMS signal, as it is clocked into the device by the JTAG clock TCK. The communication is serial so any dropped bits result in failed state transitions.

Effect of Reflections and Crosstalk

Reflections will occur during the rise time of TCK or RCK and cause the part to see two clock edges instead of one. When this occurs during a data transfer, it corrupts the data.

Effect of Ground Bounce

Ground bounce changes the voltage on the input buffers. This changes the threshold voltage of these buffers, since LVCMOS has a threshold voltage of half of the supply voltage. The ground bounce also adds a DC offset to the threshold voltage. The end result is that it raises the threshold voltage.

What happens if TCK gets double-clocked?

All of the I/O buffers in the ProASIC^{PLUS} devices are built with the same logic macro so the JTAG signals have the same performance as the rest of the device. The ProASIC^{PLUS} device datasheet specifies that the device is capable of 150 MHz system performance and up to 250 MHz internal performance. The maximum clock frequency is listed as 180 MHz. A 180 MHz clock has a period of just 5.6 ns. The clock is typically high for only half of the period or 2.8 ns. Therefore, the ProASIC^{PLUS} inputs are capable of responding to clock pulses that are 2.8 ns wide even though the programmer is only clocking the JTAG bus at 4 MHz (FlashPro TCK rate). This means that reflections or glitches that are only 2.8 ns wide will still be seen by the device's TAP controller. If the slave controller sees a 2.8 ns clock glitch when it is not in a stable state, then the glitch will affect the programming.

The stable states for the TAP controller are: Test-Logic-Reset, Run-Test/Idle, Pause-DR, and Pause-IR. All other states of the TAP controller will have a negative side effect from a clock glitch, either the state will change or extra repeated data bits will be clocked into the part.

What happens if RCK gets double-clocked?

An occasional double clocking of RCK is not as severe as double clocking for TCK. Since RCK is used for timing programming pulses, an occasional double clock just shortens the programming pulse width. Since all flash switches do not take the same amount of time to program, there is a marginal amount of over-programming that occurs for most switches. In most cases, an infrequent double clocking of RCK will reduce the over-programming, but not cause a failure. A continuous double clocking could cut all of the programming pulses in half and this could have noticeable results. Cutting the programming pulse ramp rates can cause electrical over-stress to the tunnel oxide and cause permanent damage to the device.

What is RCK and why is it needed for Internal ISP?

The ProASIC^{PLUS} device contains an internal programming controller that controls the programming of the flash switches. Voltages used during programming are based on an internal voltage reference, but the controller needs a 1 MHz clock derived from either RCK or TCK as its time reference. The part includes an internal five-bit programmable clock divider, so the external clock can be any multiple of 1 MHz, between 1 MHz and 31 MHz. The external time reference can either come from TCK or RCK. The RCK input is provided as an easy to use reference clock input. Connect an appropriate oscillator to the RCK pin and the programming controller's clock reference needs are met.

Silicon Sculptor uses the RCK input during programming because its TCK clock is under control of a program running on an internal microprocessor. Because it uses RCK, Silicon Sculptor only needs to send a TCK when it wants to communicate over the JTAG bus. If TCK is set at a constant frequency that is an integral multiple of 1 MHz and never stopped during programming, then it can be used as the reference clock instead of RCK.

The FlashPro and FlashPro Lite programmers use TCK as the reference clock so it does not need an RCK. The trade-off is that FlashPro or FlashPro Lite needs to have a hardware state controller that will move the ProASIC^{PLUS} device's internal TAP controller to a stable state whenever communication with the device is not occurring. If the PC is interrupted while it is sending data to the device's Data Register, FlashPro or FlashPro Lite must control the TMS line to move the TAP controller from the Shift-DR state into the Pause-DR state. The ProASIC^{PLUS} device can wait in the Pause-DR state until the PC resumes sending data. When the PC resumes communication, FlashPro or FlashPro Lite then needs to use the TMS line to switch the TAP controller back into the Shift-DR state.

What are the symptoms of a signal integrity problem?

A signal integrity problem can manifest itself in many ways. Because the problem shows up as extra or dropped bits during serial communication, the meaning of the communication has changed.

There is a normal variation of threshold voltage and frequency response between parts even from the same lot. Because of this, the effects of signal integrity may not always affect different devices on the same board the same way. Sometimes replacing a device appears to make signal integrity problems go away, but this is just masking the problem. Different parts on identical boards will exhibit the same problem sooner or later. As the process matures, the average speed of a device type may increase and make it more susceptible to narrow glitches. This can also uncover signal integrity problems later in the board design life cycle.

For these reasons, it is important to fix signal integrity problems early. Unless the signal integrity problems are severe enough to completely block all communication between the device and the programmer, they will show up as subtle problems. Some of the FlashPro exit codes that can cause signal integrity problems are listed below. Signal integrity problems are not the only possible cause of these errors, but this list is intended to show where problems can occur.

- Chain Integrity Test Error or Analyze Chain failure: Normally, the FlashPro Analyze Chain command expects to see 0x2 on the TDO pin. If the command reports a reading of 0x0 or 0x3, it is seeing the TDO pin stuck at 0 or 1. The only time the TDO pin comes out of tristate is when the JTAG TAP state machine is in the Shift-IR or Shift-DR states. If noise or reflections on the TCK or TMS lines have disrupted the correct state transitions, the device's TAP controller might not be in one of these two states when the programmer tries to read the device. In this case, the output is floating when the programmer does the read, and it will not match the expected value. This can also be caused by a broken TDO net. Only a small amount of data is read from the device during the Analyze Chain command, so marginal problems may not always show up during this command.
- Invalid device ID (Sculptor): Silicon Sculptor has a different set of error messages when programming Actel flash devices with bitstream files. First, it tries to read the device ID code and verify that it matches what has been selected. A common place to catch signal integrity problems when using the Sculptor's ISP module is when reading the device ID.
- Exit 7: This error occurs when programming data, read from the factory row of the device, does not match what the STAPL file expects to see. Since signal integrity problems can disrupt communication between the programmer and the device, the data read back can be affected. This

data is read before each of the STAPL file actions are executed. All ProASIC^{PLUS} devices are programmed at the factory with a design with only input pins so that there will be no I/O conflicts when soldered to a board for ISP programming. This also verifies that the factory row data is readable before the part leaves the factory. Unless the device has been damaged during handling or assembly, if you see an EXIT 7 error the first time you try to program the part, you should suspect a signal integrity problem.

- Exit 11: This error occurs during the verify stage of programming a device. After programming the design into the ProASIC^{PLUS} device, the device is verified to ensure it is programmed correctly. The verification is done by shifting the programming data into the device. Then an internal comparison is performed within the device to verify that all switches are programmed correctly. All the switches that are not programmed (0s) are verified first, followed by the switches that are programmed (1s). Since the number of flash switches in a ProASIC^{PLUS} device is huge, if the board design has any signal integrity problem with writing or reading, it is very likely to show up during verify if it has not already caused a problem.
- Verify Failed (Sculptor): Sculptor can return a verify error for the same reason that the FlashPro verify action can return an EXIT 11 error code.
- EXIT -90 programming error: There are several places in the STAPL file where testing of a status bit read from the device can result in an EXIT -90 failure. If the TAP state controller is in the wrong state, or the shift register is double clocked, the testing will not occur on the intended status bit and could result in the failure of the test. When the status bit test fails, the programmer returns an EXIT code of -90.

What do the programmer outputs look like?

Silicon Sculptor

There are three Silicon Sculptor models in use today, Silicon Sculptor, Silicon Sculptor II, and the USB connected Silicon Sculptor 3. Each Both of these require a socket module for programming. If you are doing ISP programming with a Silicon Sculptor programmer, you will be using either an SMPA-ISP-ACTEL-1, an SMPA-ISP-ACTEL-2, or an SMPA-ISP-ACTEL-3 socket module. Any of the socket modules may be used with the older two programmers but it is recommended that only SMPA-ISP-ACTEL-3 be used for new programming tasks (Figure 3).

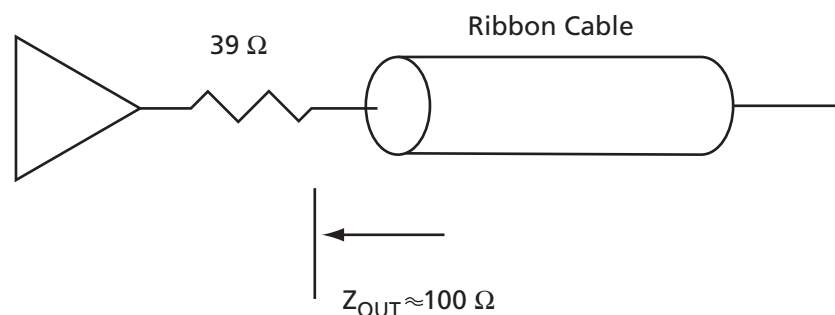

Figure 3 • ISP-1 Socket Module

When using the SMPA-ISP-ACTEL-1 socket module, the JTAG pins are driven directly by the programmer's pin drivers. These drivers are designed with a 39 Ω resistor in series with the output to raise the driver's output impedance to close to 100 Ω. The ribbon cable used with this adapter has conductors with 0.05 inch spacing. When used with the SMPA-ISP-ACTEL-1 adapter module, the characteristic impedance of this cable is approximately 100 Ω as long as all of the ground pins are connected on the target board. The output of the pin drivers provide a series termination to the transmission line. The differences between the Sculptor and Sculptor II pin drivers involve the V_{OH} level each is capable of driving, and indirectly the signal rise time. On a SMPA-ISP-ACTEL-1 socket module, the RCK frequency is 16 MHz.

The SMPA-ISP-ACTEL-2 socket module was designed with a buffer on each of the JTAG signal lines (Figure 4). The output impedance of the buffer is approximately $33\ \Omega$ so it does not provide a good termination to the $100\ \Omega$ ribbon cable. The buffer was added to improve daisy chain programming performance, but it also necessitates parallel termination of the JTAG lines to prevent reflections. The buffer has an output current limit of 20 mA, so it is limited to driving a $125\ \Omega$ termination resistor.

To terminate the ribbon cable with a lower resistance requires using AC termination with a resistor and capacitor in series. The SMPA-ISP-ACTEL-2 socket module also has a connector for the same ribbon cable used by FlashPro. The impedance of this cable is also close to $100\ \Omega$, when all of the ground pins are connected at the target board. On an SMPA-ISP-ACTEL-2 socket module, the RCK frequency was changed to 1 MHz. Using 1 MHz for RCK cuts down on cross-talk between RCK and other traces.

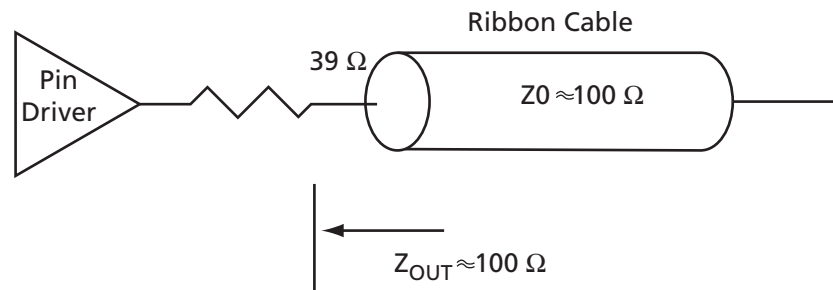

Figure 4 • ISP-2 Socket Module

The SMPA-ISP-ACTEL-3 socket module is functionally identical to the SMPA-ISP-ACTEL-2 socket module but the buffer chip has been replaced with a functionally identical buffer chip that has higher voltage tolerance. This change was made to address symptoms of EOS (Electrical Over Stress) sometimes experienced on the buffer chip on the earlier ISP module. This design change was made in January 2004. As such, it is recommended that this new module SMPA-ISP-ACTEL-3 be used for all new programming projects.

FlashPro

The output impedance of the FlashPro programmer is similar to that of the SMPA-ISP-ACTEL-1 socket module. It is an output driver with a series termination resistor. The output impedance of the JTAG drivers is about $100\ \Omega$ and matches the impedance of the narrow ribbon cable used by the FlashPro. The ribbon cable used with this adapter has conductors with 0.025 inch spacing. The impedance of this cable is close to $100\ \Omega$ when all of the ground pins are connected at the target board. The FlashPro cable connections are slightly different from those of the Silicon Sculptor. FlashPro uses one of the ground pins, pin 10, to detect that the cable is connected. This pin should still be connected to ground on the target board, but the pin is connected to a pull-up and a gate input on the FlashPro side. If the cable is not properly connected to the target board, the gate will see a logic 1 on its input instead of the 0 it expects to see. This results in an error message indicating the cable is not connected.

FlashPro Lite

The output impedance of the FlashPro Lite programmer is similar to that of FlashPro. It is an output driver with a series termination resistor. The output impedance of a JTAG driver is about $100\ \Omega$ and approximately matches the impedance of the narrow ribbon cable used by FlashPro Lite.

Header Converter

While it is not a programmer, knowing the effect of using the header converter is important in controlling signal integrity. The impedance of the header converter board is not controlled and contains stubs for each of the two unused connectors. For this reason, one of the ribbon cables used with the header converter must be as short as physically possible to limit reflections. When using the header converter, Actel recommends that the wide ribbon cable connecting the socket module to the header converter be the short cable. Tools and materials for building the wide ribbon cables are readily available making it the easier cable to build.

What should my board design look like to match the programmer(s)?

To minimize reflections at the cable to board interface, the impedance of the JTAG traces must match the cable impedance. The JTAG traces should be routed with 100Ω traces. The most critical traces are the TCK signal and the RCK signal. Note that RCK is not used with FlashPro or FlashPro Lite, so terminating it is not necessary if only using these programmers.

If you are unable to match the cable impedance because of your board stack-up, another option is to buffer the JTAG signals at the programming header and terminate the buffer inputs in the cable's characteristic impedance. The output of the buffer can then drive whatever impedance trace your board stack-up dictates. This option is shown in Figure 5.

This buffer can either be on your board or it can be an adapter that plugs into the programming header. You may still need to terminate the buffered clock signals to match the impedance of your board traces. Treat TCK and RCK as 200 MHz clocks in your layout to be safe.

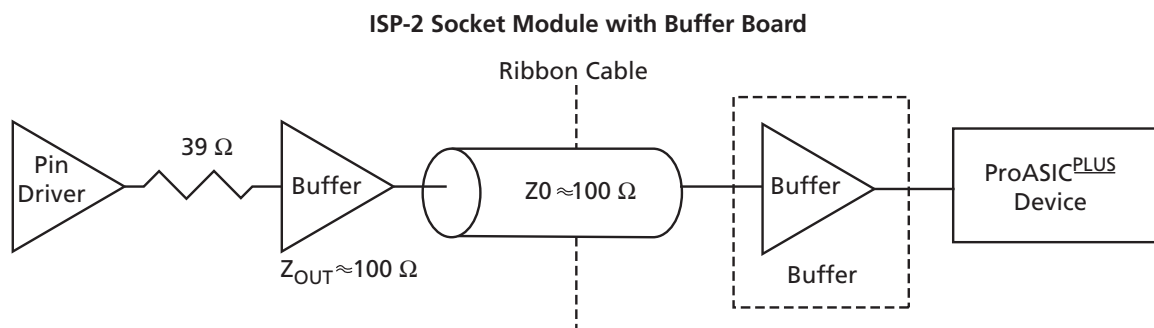

Figure 5 • Buffering JTAG Signals

Termination

The need to terminate the JTAG signals depend on the complexity and layout of your board. If your board design is a simple board with only one ProASIC^{PLUS} device, the programming header is next to the part, and you are using either of the FlashPro programmers or the SMPA-ISP-ACTEL-1 socket module, then you do not need additional terminators on your board.

If your board contains multiple devices on the JTAG chain, the distance between the programming header and the ProASIC^{PLUS} device is large, or if before you are employing the SMPA-ISP-ACTEL-2 socket module, then you should consider using some form of termination. At the very least, the TCK line should be terminated. If you want to use the Silicon Sculptor programmer, then the RCK line will also need to be terminated. An 82 Ω resistor in series with a 220 pF capacitor has given good results in our testing. The correct values for any given board will need to be determined on a case-by-case basis. Providing generic land patterns for the terminators during the board layout will give you the most flexibility when the final termination values are selected.

The type of termination to use depends on the design and layout of each individual board. Series termination at the driver works best when all device loading is at the end of the net. This occurs when only one device is connected to the clock line or when two devices are both connected at the end of the line. With series termination, the series resistor and the trace impedance make up a voltage divider. If both the output resistance and trace impedance are matched, then the signal sent down the wire is only half the normal voltage swing. With no termination at the end of the trace, when the signal reaches the end, it is reflected back to the driver with a reflection coefficient of +1. The devices at the end of the line will see a normal signal swing and the reflection from the open-ended line will be absorbed at the driver. If there is a device attached half way down a long trace, then there is the possibility that this device will see the signal rise to the threshold voltage where it will stay until the reflection from the end of the line gets back to this device. What is considered long depends on the rise time of the signal and the input frequency response of the device.

The cable lengths used in Figure 6 on page 10 were exaggerated to show this effect. This picture used a three-foot ribbon cable from a SMPA-ISP-ACTEL-1 socket module connected to a header converter with the normal 18 inch narrow ribbon cable to a buffer chip.

The pause at threshold is clearly visible when looking at the header converter to simulate a device 18 inches from the end of the net. Because of the slight impedance mismatch between the two cables and the effect of the header converter, the signal looks even worse at the input to the buffer (Figure 7).

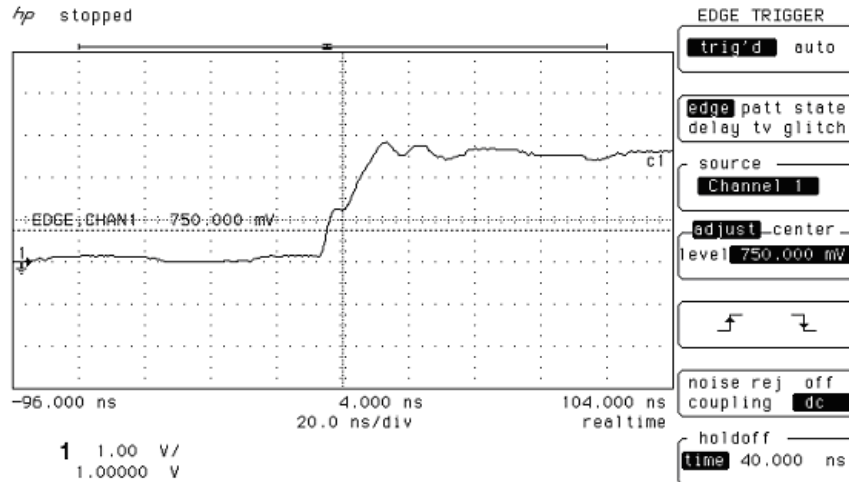

Figure 6 • Midpoint at Point Source Terminated Net

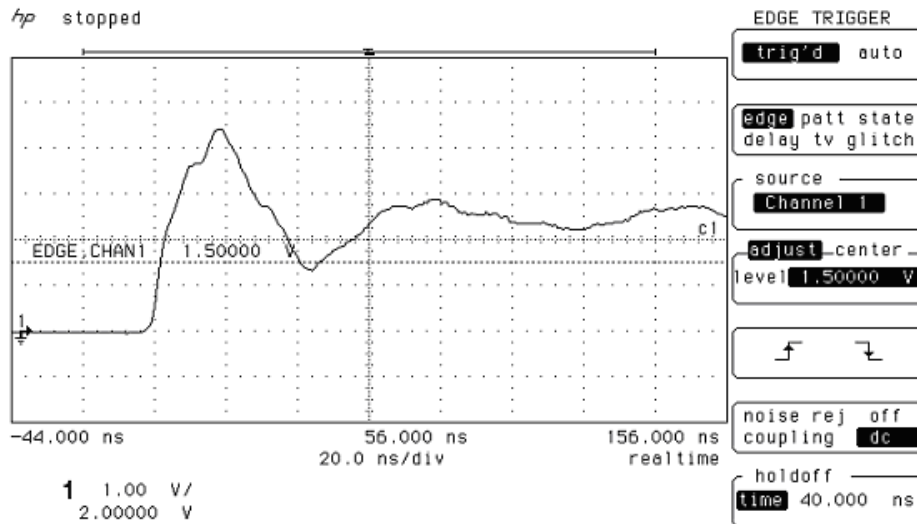

Figure 7 • Buffer Input

If this was the TCK input to a ProASIC^{PLUS} device, it would cause double clocking and you would not be able to communicate with the device. The output of the buffer shows this false clock in Figure 8.

In these pictures, it is easy to see the problem. Usually the problem is not so pronounced, and it takes at least a 500 MHz bandwidth oscilloscope to see the evidence. The scope trace in Figure 9 shows signs of overshoot, but unless you look closely, you will miss the double clocking that it has captured. The original waveform is shown on the left side in Figure 9.

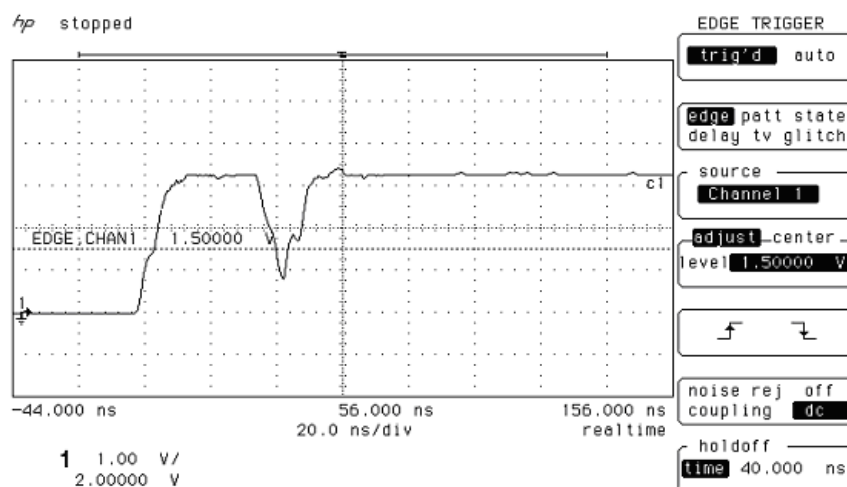

Figure 8 • Buffer Output

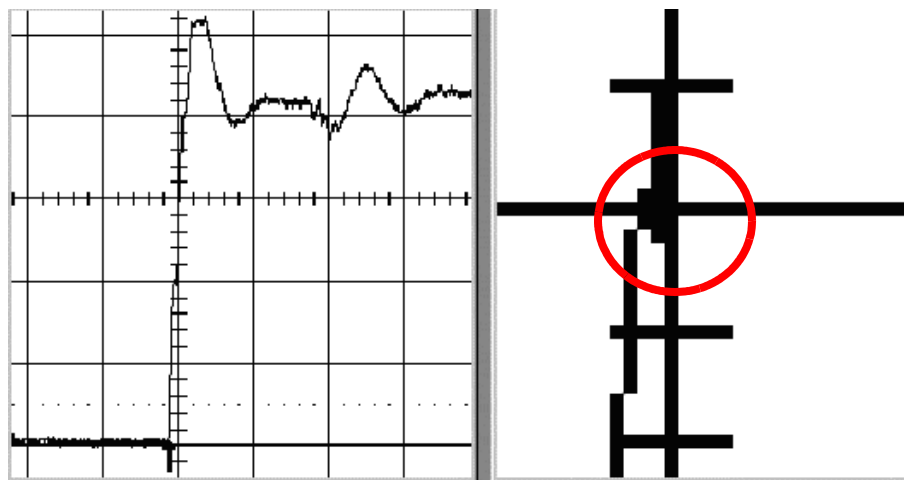

Figure 9 • Threshold Glitch

On the right is a magnified image of the waveform as it crosses the threshold. The circled area shows where double clocking may be occurring. Whether this reflection will cause double clocking depends on the threshold voltage of this input as well as the frequency response of the input. Both of these parameters will vary from device to device. Therefore, what works with one device on a prototype board might not always work in production when variations in board impedance are also involved. Even with a single board, replacing the device may cause a working board to fail programming just because the new device has a slightly different threshold voltage. The solution is to improve the signal integrity of the nets, eliminate impedance discontinuities, and terminate the clock lines.

Another signal integrity consideration is limiting the length of parallel traces. This helps to keep crosstalk between traces to a minimum. Please see the “References” section on page 16 for more information on crosstalk.

Programming Header

FlashPro and FlashPro Lite programmers are designed to use the small programming header. If you are using either programmer, it is recommended that you use the small programming header on your target board. If you are using the large programming header on your target board, you are required to use a header converter with your programmer. (Refer to Table 3 on page 15 for part numbers).

No plug-in connector is needed for ProASIC^{PLUS} devices. ProASIC^{PLUS} devices' V_{DD} , V_{DDP} , V_{PP} and V_{PN} only need to be connected to the programming header if they are not supplied by the target during programming. The programmer will supply V_{DD} , V_{DDP} , V_{PP} and V_{PN} if they are not supplied by the target during programming. If the target supplies V_{DD} , V_{DDP} , V_{PP} and V_{PN} , connecting to the header is optional. ProASIC^{PLUS} devices' GND, TCK, TDI, TDO, and TMS must be connected to the programming header. RCK is optional (Figure 2 on page 3).

ProASIC^{PLUS} devices also use the JTAG (IEEE Standard 1149.1 1990) pins TCK, TMS, TDI, and TDO for programming. The TRST pin, an optional JTAG pin, is not used during programming, but it must remain high during programming. This can be done from the FlashPro software. For Silicon Sculptor, the RCK pin is also required during programming; it is not required for FlashPro. Figure 10 and Figure 11 on page 13 show a programming header on a PCB and how it connects to a programmer.

ISP programming can also be done with the Silicon Sculptor I, Silicon Sculptor II, or Silicon Sculptor 3 programmers. When using the SMPA-ISP-ACTEL-1 Sculptor adapter module, use the wide 26 pin programming header on your board, because it is the only connector supported by the SMPA-ISP-ACTEL-1 socket module. When using the SMPA-ISP-ACTEL-2 or SMPA-ISP-ACTEL-3 Sculptor adapter modules, use either the wide or the narrow 26-pin programming header on your board, because both connectors are supported by the SMPA-ISP-ACTEL-3- KIT socket module. You can still use the header converter if you are using the SMPA-ISP-ACTEL-1 programming adapter module. See “Header Converter” section on page 14.

In order to use the ISP programming module on the Silicon Sculptor, you must explicitly select the ISP programming module in the Silicon Sculptor software. This is done by selecting the package of the target device as “ISP”. For example, to program an APA750-PQ208 via Sculptor ISP, select **APA750-ISP** as the target device, and do NOT select APA750-PQ208. Figure 12 on page 13 shows this selection.

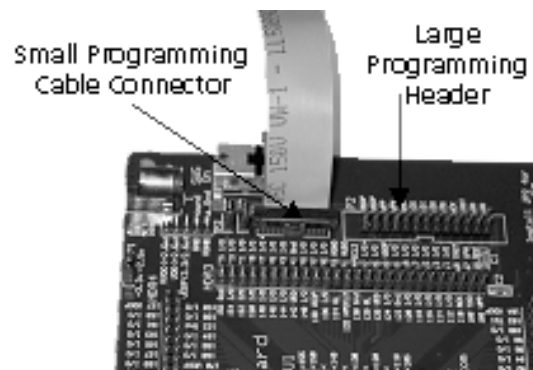

Figure 10 • Small Cable Connector

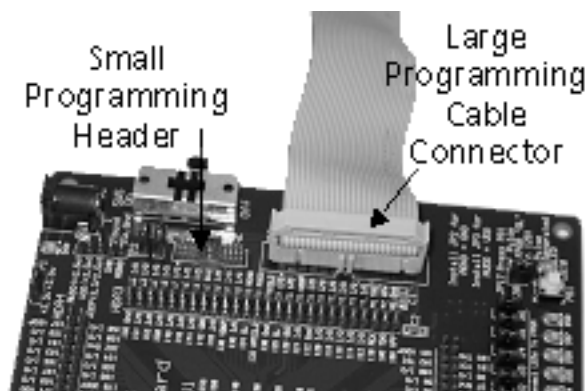

Figure 11 • Large Cable Connector

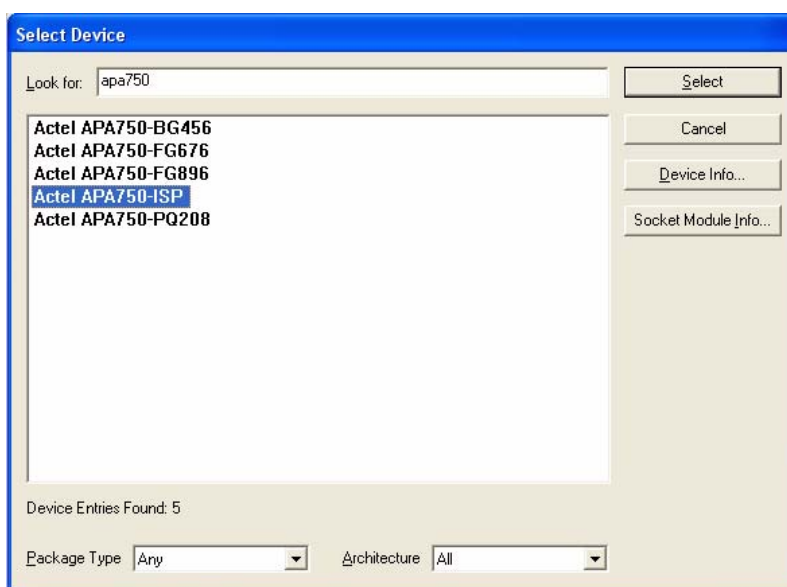

Figure 12 • ISP Programming Module in Silicon Sculptor Software

General Programming Information

Actel recommends checking the device ID on the ISP board design before programming a device by reading the device ID from the device using Silicon Sculptor II or FlashPro. If there is a problem, the programmer will fail with a "bad IDCODE" error message. If the reason for the failure cannot be found in the connection with the circuitry or the programming voltages, it is possible that the failure was caused by noise on the TCK or RCK signals. It is important to take all noise precautions into account for the TCK and RCK signals.

Before programming a device, check the following:

- Make sure that the "1" level of all signals driving the device is within ± 0.8 V of V_{DDP}
- Make sure that all ESD protection measures are taken.

While programming a device, do not interrupt programming.

Header Converter

Actel also provides a header converter (Actel Part Number: Header-Converter) that enables the FlashPro programmer to be used with the older 100 mil spacing header. The header converter also provides an eight-pin connection from the programmer to the board, further reducing the board space required to perform ISP. This should only be used when space is critical because this could increase the chance of noise and failed programming (Figure 13). If an eight-pin cable is used, a shorter cable will give better signal integrity.

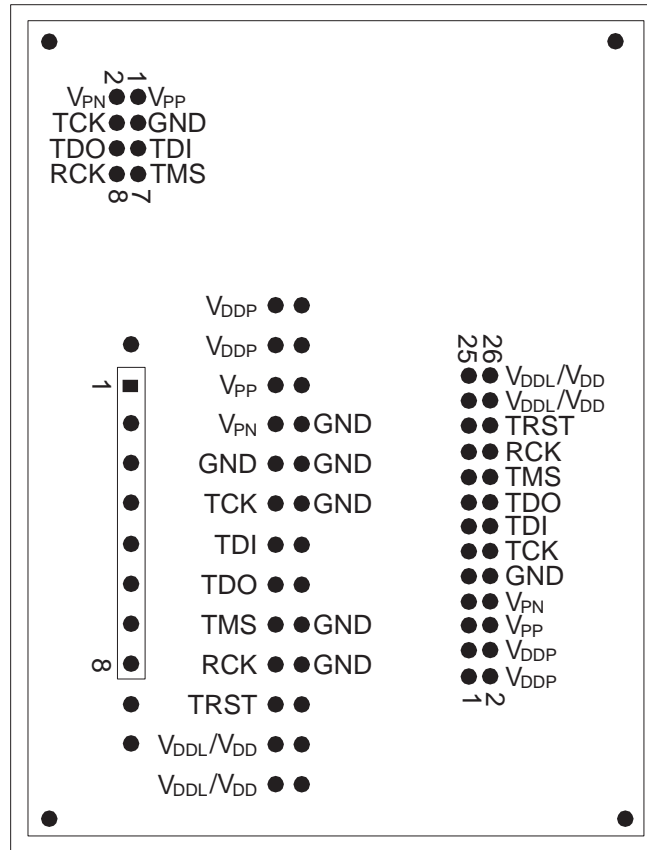

Figure 13 • Head Converter Assembly

Table 2 lists the pin numbers and names for Figure 13.

Table 2 • Pin Numbers and Names

Pin Number	Pin Name
1	V _{PP}
2	V _{PN}
3	GND
4	TCK
5	TDI
6	TDO
7	TMS
8	RCK

Programmer Ordering Codes

Table 3 lists the programmer ordering codes.

Table 3 • Programmer Ordering Codes

Description	Vendor	Ordering Code	Comment
FlashPro ISP Programmer	Actel	FlashPro	Supports Small Programming Header or Large Header through header converter (not included)
Silicon Sculptor 3	Actel	SILICON-SCULPTOR 3	USB-based connection to PC (supports up to 12 programmers via powered hubs). Requires add-on Adapter Modules to support devices.
Silicon Sculptor II	Actel	SILICON-SCULPTOR II	Parallel-port, up to 2 programmers may be chained to a single PC. Requires add-on Adapter Modules to support devices.
Silicon Sculptor ISP Module	Actel	SMPA-ISP-ACTEL-3-KIT	Ships with both Large and Small Header Support
Concurrent Programming Cable	Actel	SS-EXPANDER	Used to cascade multiple Silicon Sculptors together
Software for Silicon Sculptor	Actel	SCULPTOR-SOFTWARE-CD	http://www.actel.com/custsup/updates/silisculpt/
ISP Cable for Small Header	Actel	ISP-CABLE-S	Supplied with ISP Module Kit
ISP Cable for Large Header	Actel	PA-ISP-CABLE	Supplied with ISP Module Kit
Header Converter	Actel	Header-Converter	Converts from Small to Large Header
Small Programming Header	Samtec	FTSH-113-01-L-D-K	Supported by FlashPro, FlashPro Lite, and Silicon Sculptor
Large Programming Header 0.062 Board Thickness	3M	3429-6502	Supported by Silicon Sculptor by default and FlashPro with Header Converter
Large Programming Header 0.094-0.125 Board Thickness	3M	3429-6503	Supported by Silicon Sculptor by default and FlashPro with Header Converter
Plug in Header Small	Actel	SMPA-ISP-HEADER-S	Required for Small Header for ProASIC only, not used for ProASIC ^{PLUS}
Plug-in Header	Actel	SMPA-ISP-HEADER	Required for Large Header for ProASIC only, not used for ProASIC ^{PLUS}
Vacuum Pen for PQ, TQ, VQ fewer than 208 pins	Actel	PENVAC	
Vacuum Pen for PQ, TQ, VQ greater/equal to 208 pins	Actel	PENVAC-HD	
Small Programming Header	Samtec	FTSH-113-01-L-DV-K	Surface mount header with vertical pins. This header could be used due to board thickness issues. Customer needs to consider the physical stress specs accordingly.
Small Programming Header	Samtec	FTSH-113-01-L-DH-K	Surface mount header with horizontal pins. This header could be used due to board thickness issue. Customer needs to consider the physical stress specs accordingly.

Related Documents

For more information about Programming with ProASICPLUS devices, please refer to the following documents:

- IEEE 1149.1-1990 Standard Test Access Port and Boundary Scan Architecture
- Designer User's Guide

Silicon Sculptor 3

To find a description of Silicon Sculptor 3, Silicon Sculptor II, and Silicon Sculptor I, go to:

<http://www.actel.com/products/tools/silisculpt/index.html>.

Silicon Sculptor User Guides:

- Windows User's Guide:

http://www.actel.com/documents/SiliSculptII_Sculpt3_ug.pdf

- DOS User's Guide:

http://www.actel.com/documents/sculptor_DOS_ug.pdf

- Calibration Validation Procedure for Silicon Sculptor Family Programmers:

http://www.actel.com/documents/SiliSculptProgCali_UG.pdf

- ProASIC Daisy-Chain Programming:

http://www.actel.com/documents/daisy_chain_UG.pdf

Includes hardware and software setup, calibration, use instructions, and troubleshooting/error message guide.

FlashPro User's Guides:

To find detailed information about FlashPro, go to:

http://www.actel.com/documents/flashpro_ug.pdf

Includes hardware and software setup, self-test instructions, use instructions, and a troubleshooting/error message guide.

ChainBuilder User's Guide

http://www.actel.com/documents/chainbuilder_ug.pdf

Application Notes

Performing Internal In-System Programming Using Actel's ProASIC^{PLUS} Devices—Contains a description of how to use an on-board processor to perform ISP.

http://www.actel.com/documents/APA_Microprocessor_AN.pdf

Implementation of Security in Actel's ProASIC and ProASIC^{PLUS} Flash-Based FPGAs—Describes the different types of security available in Flash devices and how to implement the security.

http://www.actel.com/documents/Flash_Security_AN.pdf

References

- MECL System Design Handbook, ON Semiconductor Rev. 1A, May-1988 Fourth Edition Author Williams R Blood, Jr. See chapters 3, 4, and 7. <http://www.onsemi.com/pub/Collateral/HB205-D.PDF>
- Johnson, H.W. & M.Graham "High-Speed Digital Design, A Handbook of Black Magic," PTR Prentice Hall, Englewood Cliffs, NJ 1993 Prentice Hall, 1993; ISBN 0-13-395724-1 <http://signalintegrity.com/books.htm>
- Termination Placement in PCB Design Douglas Brooks, UltraCAD Design Inc. Available from Mentor Graphics at http://www.mentor.com/pcb/tech_papers.cfm under heading High-Speed Design
- Transmission Line Terminations, It's The End That Counts! Douglas Brooks, UltraCAD Design Inc.

Available from Mentor Graphics at http://www.mentor.com/pcb/tech_papers.cfm under heading High-Speed Design.

List of Changes

The following table lists changes that were made in the current version of the document.

Table 4 • List of Changes

Previous Version	Changes in Current Version 51900032-5/10.07	Page
51900032-4/12.06	In the "ProASICPLUS Devices – APA075, APA150, APA300" section, the total combined distance of the programming cable and the trace length on the board for each pin was changed from 30 inches to 18 inches.	4
51900032-3/5.05	This document was updated to include Silicon Sculptor 3 information.	N/A
	The "Programming Header" section was updated to include information about using ISP in Silicon Sculptor software.	12
51900032-2/06.04	Table 1 was updated.	2
	Figure 2 was updated.	3
	The "Programmer Specific Requirements" was updated.	4
51900032-1/05.03	The "Board Considerations" was updated.	3
	The "Programming Header" was updated.	12

Actel and the Actel logo are registered trademarks of Actel Corporation.
All other trademarks are the property of their owners.



<http://www.actel.com>

Actel Corporation

2061 Stierlin Court
Mountain View, CA
94043-4655 USA

Phone 650.318.4200

Fax 650.318.4600

Actel Europe Ltd.

River Court, Meadows Business Park
Station Approach, Blackwater
Camberley, Surrey GU17 9AB
United Kingdom

Phone +44 (0) 1276 609 300

Fax +44 (0) 1276 607 540

Actel Japan

EXOS Ebisu Bldg. 4F
1-24-14 Ebisu Shibuya-ku
Tokyo 150 Japan

Phone +81.03.3445.7671

Fax +81.03.3445.7668

www.jp.actel.com

Actel Hong Kong

Suite 2114, Two Pacific Place
88 Queensway, Admiralty
Hong Kong

Phone +852 2185 6460

Fax +852 2185 6488

www.actel.com.cn